

CROSSFIRE™

B R A S S B U R N E R S

Manufactured by
WarmingTrends™



INSTALLATION MANUAL

For the CROSSFIRE™ Brass Burners
and Ignition Systems

General Warnings and Information 4

Selecting a location for your fire feature 4

Construction of enclosure 5

General Fire Pit Installation 5

Media Installation 6

Fire Feature Operation 6

Lighting Instructions 7

Maintenance 7

Troubleshooting 7

Warranty 8

INSTALLATION FOR ALL MODELS

60K - 120K BTU System with FLKV12..... 9
(Match Lit, Standard Ignition, Premium Ignition)

121K - 249K BTU System with FLKV34 and FLKV34FIT180..... 13
(Match Lit, Standard Ignition, Premium Ignition)

250K - 299K BTU System with DFLKV34 and DFLKV34FIT250..... 16
(Match Lit, Standard Ignition, Premium Ignition)

300K + Higher BTU System with DFLKV34 and DFLKV34FIT300..... 21
(Match Lit, Standard Ignition, Premium Ignition)

Push Button Ignition Installation 26

Parts Glossary 28

CERTIFIED UNITS

Compliance with the following codes:

1. 2018, 2015, 2012, and 2009 *International Fire Code*® (IFC)
2. 2018, 2015, 2012, and 2009 *International Fuel Gas Code*® (IFGC)
3. 2015, 2012 and 2009 *Uniform Mechanical Code*® (UMC)*
4. 2015 and 2010 *Natural Gas and Propane Installation Code***

*Uniform Plumbing Code is a copyrighted publication of the International Association of Plumbing and Mechanical Officials
**Copyrighted publication of Canadian Standard Association



ICC-ES Report PMG-1213

Compliance with the following standards:

1. ANSI Z21.97/CSA 2.41-2017 Outdoor Decorative Gas Appliances

CERTIFIED MODELS

MATCH LIT:

Model # CFB60 NG/LP as match lit
 Model # CFB120 NG/LP as match lit
 Model # CFB180 NG/LP as match lit
 Model # CFB290 NG/LP as match lit
 Model # CFBL90 NG/LP as match lit
 Model # CFBL110 NG/LP as match lit
 Model # CFBL130 NG/LP as match lit
 Model # CFBL150 NG/LP as match lit
 Model # CFBL190 NG/LP as match lit
 Model # CFBL210 NG/LP as match lit
 Model # CFBL250 NG/LP as match lit
 Model # CFBL270 NG/LP as match lit
 Model # CFBL320 NG/LP as match lit
 Model # CFB60 2XL NG/LP as match lit
 Model # CFBH120 NG/LP as match lit
 Model # CFBH160 NG/LP as match lit
 Model # CFBH200 NG/LP as match lit
 Model # CFBH240 NG/LP as match lit
 Model # CFBH260 NG/LP as match lit
 Model # CFBH300 NG/LP as match lit
 Model # CFBH340 NG/LP as match lit

Model # CFBH420 NG/LP as match lit
 Model # CFBT110 NG/LP as match lit
 Model # CFBT170 NG/LP as match lit
 Model # CFBT230 NG/LP as match lit
 Model # CFBT290 NG/LP as match lit
 Model # CFBT350 NG/LP as match lit
 Model # CFBT410 NG/LP as match lit
 Model # CFBT470 NG/LP as match lit

3V BATTERY OPERATED UNITS

Model # CFB60 NG/LP with 3VIK
 Model # CFB120 NG/LP with 3VIK
 Model # CFBL90LP NG/LP with 3VIK
 Model # CFBL110LP NG/LP with 3VIK
 Model # CFBL130LP NG/LP with 3VIK
 Model # CFB60 2XL NG/LP with 3VIK
 Model # CFBH120LP NG/LP with 3VIK
 Model # CFBT110LP NG/LP with 3VIK

24 VOLT STANDARD ELECTRONIC IGNITION SYSTEMS - Standard Capacity
 Model # CFB60 NG/LP with 24VIKSC
 Model # CFB120 NG/LP with 24VIKSC
 Model # CFB180 NG/LP with 24VIKSC
 Model # CFBL90 NG/LP with 24VIKSC
 Model # CFBL110 NG/LP with 24VIKSC
 Model # CFBL130 NG/LP with 24VIKSC
 Model # CFBL150 NG/LP with 24VIKSC
 Model # CFBL190 NG/LP with 24VIKSC
 Model # CFB60 2XL NG/LP with 24VIKSC
 Model # CFBH120 NG/LP with 24VIKSC
 Model # CFBH160 NG/LP with 24VIKSC
 Model # CFBH200 NG/LP with 24VIKSC
 Model # CFBT110 NG/LP with 24VIKSC
 Model # CFBT170 NG/LP with 24VIKSC

24 VOLT STANDARD ELECTRONIC
IGNITION SYSTEMS - High Capacity
Model # CFB290 NG/LP with 24VIKHC
Model # CFB300 NG/LP with 24VIKHC
Model # CFBL210 NG/LP with 24VIKHC
Model # CFBL250 NG/LP with 24VIKHC
Model # CFBL270 NG/LP with 24VIKHC
Model # CFB320 NG/LP with 24VIKHC
Model # CFBH240 NG/LP with 24VIKHC
Model # CFBH260 NG/LP with 24VIKHC
Model # CFBH300 NG/LP with 24VIKHC
Model # CFBH340 NG/LP with 24VIKHC
Model # CFBH420 NG/LP with 24VIKHC
Model # CFBT230 NG/LP with 24VIKHC
Model # CFBT290 NG/LP with 24VIKHC
Model # CFBT350 NG/LP with 24VIKHC

Model # CFBL150 NG/LP with P24VIKSCCG
Model # CFBL190 NG/LP with P24VIKSCCG
Model # CFBL210 NG/LP with P24VIKSCCG
Model # CFBL250 NG/LP with P24VIKSCCG
Model # CFBL270 NG/LP with P24VIKSCCG
Model # CFB60 2XL NG/LP with P24VIKSCCG
Model # CFBH120 NG/LP with P24VIKSCCG
Model # CFBH160 NG/LP with P24VIKSCCG
Model # CFBH200 NG/LP with P24VIKSCCG
Model # CFBH240 NG/LP with P24VIKSCCG
Model # CFBH260 NG/LP with P24VIKSCCG
Model # CFBT110 NG/LP with P24VIKSCCG
Model # CFBT170 NG/LP with P24VIKSCCG
Model # CFBT230 NG/LP with P24VIKSCCG
Model # CFBT290 NG/LP with P24VIKSCCG

24 VOLT PREMIUM ELECTRONIC
IGNITION SYSTEMS - Standard Capacity
Model # CFB60 NG/LP with P24VIKSCCG
Model # CFB120 NG/LP with P24VIKSCCG
Model # CFB180 NG/LP with P24VIKSCCG
Model # CFB290 NG/LP with P24VIKSCCG
Model # CFBL90 NG/LP with P24VIKSCCG
Model # CFBL110 NG/LP with P24VIKSCCG
Model # CFBL130 NG/LP with P24VIKSCCG

24 VOLT PREMIUM ELECTRONIC
IGNITION SYSTEMS - High Capacity
Model # CFB300 NG/LP with P24VIKHCCG
Model # CFBL320 NG/LP with P24VIKHCCG
Model # CFBH300 NG/LP with P24VIKHCCG
Model # CFBH340 NG/LP with P24VIKHCCG
Model # CFBH420 NG/LP with P24VIKHCCG
Model # CFBT350 NG/LP with P24VIKHCCG
Model # CFBT410 NG/LP with P24VIKHCCG
Model # CFBT470 NG/LP with P24VIKHCCG

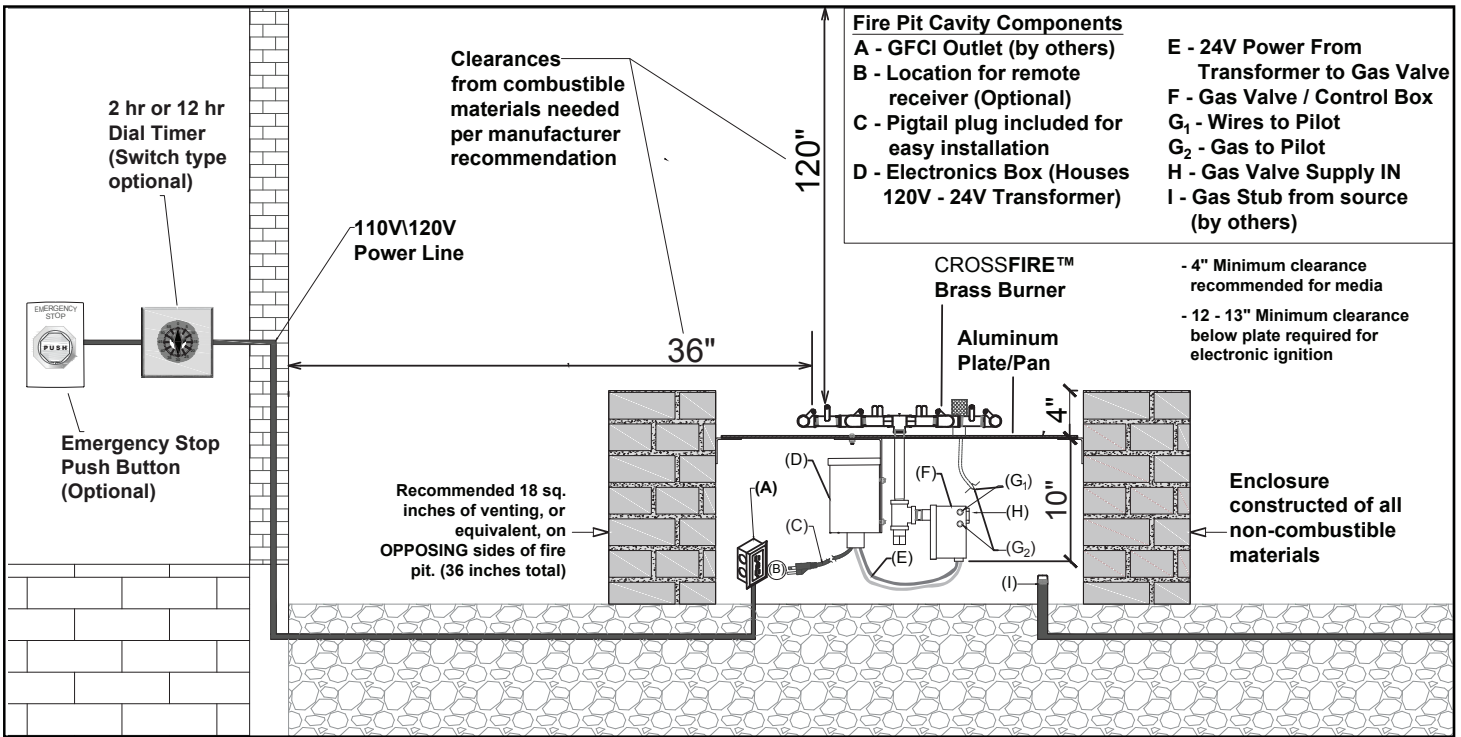

GENERAL WARNINGS

WARNING: YOU MUST READ OWNERS MANUAL IN ITS ENTIRETY PRIOR TO INSTALLATION AND/OR OPERATION.

WARNING: FOR OUTDOOR USE ONLY.

WARNING: Improper installation, adjustment, alteration, service, or maintenance can cause injury or property damage. Read the installation, operating, and maintenance instructions thoroughly before installing or servicing this equipment.

WARNING: Do not store or use gasoline or other flammable vapors and liquids in vicinity of this or any other appliance.

WARNING: LP-cylinder not connected for use shall not be stored in the vicinity of this appliance.

WARNING: If you smell gas:

- Shut off gas to appliance.
- Extinguish any open flame.
- If gas odor continues, keep away from appliance and immediately call gas supplier or fire department.

WARNING: DO NOT USE OXYGEN MIXERS WITH CROSSFIRE™ BRASS BURNERS. Mixers create leakage in the cavity of the pit and are a serious hazard.

GENERAL INFORMATION

Carefully follow the instructions in this manual to prevent personal injury or property loss. Instructions are updated as needed. It is the installer's responsibility to periodically review instructions for applicable updates.

WARNING: This Owner's Manual contains critical information for the safe installation and operation of the fire features listed in this manual. All instructions must be strictly followed for safe installation and operation. Warranty is void if not followed.

WARNING: It is the installer's responsibility to ensure a safe installation and to educate the end user as to proper operation. Installer must leave this manual with the end user.

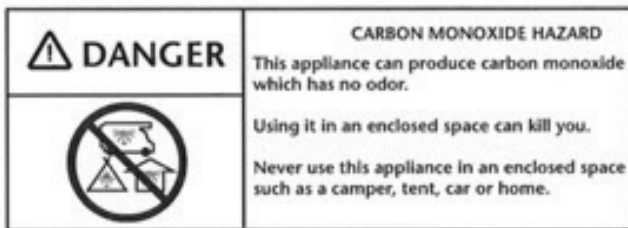

WARNING: We suggest that our products be installed by professionals that are locally licensed by the authority having jurisdiction in gas piping. We suggest that our products be serviced annually by a licensed plumber. Installer must follow all instructions carefully to ensure proper performance and safety. Warming Trends™ is not responsible for your actions.

WARNING: Never alter product or configuration in any way. Alterations can damage the product and cause harm to the end user. Warranty is void if any modification is made to product.

WARNING: FOR REMOTE CONTROL USE: To prevent accidental startup from unwanted Remote Control signals it is the responsibility of the end user to turn off power to electric outlet for the remote-control receiver when the fire-pit is not in use via wall switch or breaker.

WARNING: Product is not intended to be a starter for wood or other combustibles.

WARNING: It is the responsibility of the installer to follow ALL LOCAL CODES concerning the installation and operation of the fire pit. In the absence of local codes, please follow:

- Fixed piping system: The National Fuel Gas Code, ANSI Z223.1/ NFPA 54 or International Fuel Gas Code.
- Electrical ground: The National Electrical Code, ANSI/NFPA 70.

WARNING: Only use gas/fuel type specified for this fire pit. See label on the burner. Verify correct gas/fuel type and pressure. Never use an alternative fuel, included but not limited to biofuel, ethanol, lighter fluid or any other alternative fuel other than Liquid Propane or Natural Gas.

WARNING: Gas pressure and type should be checked prior to use and installation.

MATCH LIGHT	Minimum	Maximum
Natural Gas	3.5" W.C.	7.0" W.C.
Liquid Propane	11.0" W.C.	13.0" W.C.

STANDARD - 24VIKSC & 24VIKHC	Minimum	Maximum
Natural Gas	3.0" W.C.	5.0" W.C.
Liquid Propane	8.0" W.C.	12.0" W.C.

3V - 3VIK	Minimum	Maximum
Natural Gas	4.5" W.C.	10.0" W.C.
Liquid Propane	11.0" W.C.	13.0" W.C.

PREMIUM - P24VIKSC & P24VIKHC	Minimum	Maximum
Natural Gas	3.5" W.C.	14.0" W.C.
Liquid Propane	8.0" W.C.	14.0" W.C.

SELECTING A LOCATION FOR YOUR FIRE FEATURE

WARNING: All fire pits, match lit kits, spark ignition, and electronic ignition systems are designed and intended for outdoor use only.

WARNING: For electronic ignition models, there must be an electrical shut off (wall switch or breaker) on the exterior of the fire pit or on adjacent wall to allow for emergency shutdown and maintenance. Distance may be determined by local code.

WARNING: All fire pits must have a gas shutoff located outside of the fire pit to allow for emergency shut off and maintenance.

WARNING: Select a location where the fire pit can be attended during operation. Never leave an operating fire pit unattended or by someone not familiar with its operation or emergency shut off locations.

WARNING: Both children and adults should be alerted to the hazards of high surface temperatures and should remain a safe distance away to avoid burns and clothing ignition.

WARNING: Young children should be carefully supervised when they are in the area of a fire pit.

WARNING: Clothing or other flammable materials should not be placed on or near fire pit.

WARNING: Fire pits create very high temperatures - Combustibles must be located far enough away that there is no risk of ignition.

IMPORTANT: It is recommended that material such as granite, marble or other dense stone be kept an appropriate distance away from flame due to risk of cracking. Manufacturer is not responsible for damage to any fire pit material for any reason.

FIRE PIT CLEARANCES

- 36" horizontally from any combustible structure.
- Overhead clearance should be a minimum of 120" from combustible structures.
- Choose a location that allows easy access for installation and maintenance of the fire pit.
- Pick a location that allows sufficient horizontal room to enjoy the fire pit while allowing a safe distance from the heat and flame.
- Always consult with local municipality regarding any local code requirements

CONSTRUCTION OF ENCLOSURE

WARNING: Mount the key valve on the outside exterior of enclosure, away from the flame, to turn unit on/off.

WARNING: All fire pits must have a gas shutoff on the outside of the fire pit to allow for emergency shut off and maintenance.

WARNING: Key valve should be mounted below the plate line and through the side wall of the vessel. Consult qualified installer or gas technician for proper installation.

WARNING: For electronic ignition models, there must be an electrical shut off (wall switch or breaker) on the exterior of the fire pit or on adjacent wall to allow for emergency shutdown and maintenance. Verify correct power supply.

WARNING: Always use proper materials and construction for gas supply, power and enclosure. Materials must be non-combustible in both initial installations as well as over time.

WARNING: For electronic ignition models requiring power supply - a qualified, licensed electrician must install power supply. An outdoor NEMA rated GFCI Receptacle outlet should be installed on the interior of the enclosure above grade to supply power to system.

WARNING: Minimum requirement: Incorporate 1 vent on at least two opposing sides (2 vents total) at a minimum size of 18 sq. inches each (Example: 3"x 6" or larger). Installation of the vents in the mid to lower area of the enclosure is recommended. Ventilation allows for heat and/or residual fuel to escape. Failure to properly vent enclosure may result in the fire pit overheating or explosion. Overheating could lead to heat damage to internal components. Some enclosures may require more ventilation based on material, size, and extended use. The vent may serve as a drain as well when installed at bottom sidewall to prevent water build up. Always consult with local municipality regarding any local code requirements

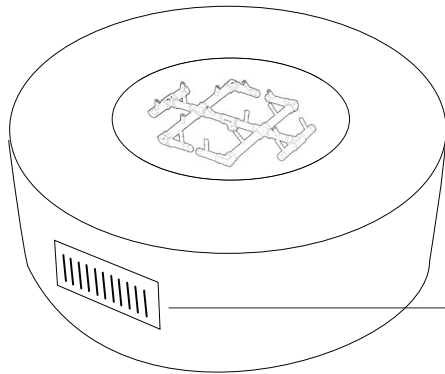

WARNING: Ready-to-Finish Kits come with Fire Pit Vent Kit (FPVK). Vents do not come pre-installed on Ready-to-Finish Kit as placement and installation depends on veneer. Vents to be installed by contractor on site.

WARNING: The interior space of the enclosure surrounding the valve box cannot be filled with any material (gravel, crushed rock, concrete, etc.).

WARNING: The fire pit assembly should be recessed 4" - 6" from the top of the enclosure to protect flame from being blown out. Some areas may require deeper recession.

WARNING: The enclosure must be constructed on a stable surface. The weight of the fire feature must be supported by the plate or pan and not by any control/valve box. For electronic ignition models the control/valve box must be above grade with adequate drainage to prevent water damage to the controls inside the box. Installer is responsible for ensuring there is enough space for electronics - see technical drawings provided by manufacturer. Installer is responsible to ensure that the structure is level. Blocks, bricks or L-brackets can be used to build a support ledge for the system plate or pan.

WARNING: It is the responsibility of the installer to provide proper installation to allow for easy accessibility for service and/or repairs. Installer must not build capstone inner ledge over outer lip of plates or pans (unless access panel door or alternate access is incorporated). Building capstone inner ledge over outer edge of plates or pans will impede access to system and result in the need to crack capstones to gain access. Warming Trends is not responsible for damage to enclosure for any reason whatsoever.

GENERAL FIRE PIT INSTALLATION

WARNING: Read all warnings prior to installing your fire feature

WARNING: All gas products should be installed by qualified professionals that are locally licensed by the authority having jurisdiction in gas piping.

WARNING: We suggest that our products be serviced annually by a licensed plumber.

WARNING: It is the installer's responsibility to follow installation instructions carefully in order to ensure a safe installation, safe operation and safe ongoing servicing.

WARNING: You must confirm this appliance is built for gas use - Natural Gas or Liquid Propane. Do not use Natural Gas appliance with Liquid Propane or Liquid Propane appliance with Natural Gas. Refer to the labeling on the appliance to confirm gas type.

WARNING: Fuel line sizing is the responsibility of the installer and must be able to supply the stated maximum BTU listed for each product.

WARNING: Gas Plumbing Connections: Use only joint compound or thread sealant or tape specific to gas use that is resistant to all gases. Apply joint compound, thread sealant or tape to all male pipe fittings only and DO NOT use on FLARED fittings. Be sure to tighten every joint securely.

WARNING: To prevent damage to burner, unhook fire feature from gas supply during pressure leak tests of the fire feature.

WARNING: Before use, be sure to test all gas connections for leaks. Do not use fire feature if there is evidence of leaking gas. If leak is suspected, turn off main gas supply immediately and call a qualified gas technician to repair.

WARNING: During Media Installation - when filling the pan with lava rock and/or decorative glass and/or any covering material including log sets, the instructions for Media must be followed.

WARNING: For electronic ignition systems, which have an extended or detached valve box, the area in which the valve box is installed must conform with all installation requirements, including but not limited to location, construction, venting and local codes. Failure to do so may result in personal injury, property damage or explosion.

WARNING: If using an LP bottle/tank, position bottle/tank at safe distance away from flame. Do not place LP bottle/tank inside the enclosure.

WARNING: Use only the key provided to turn the gas valve. Use only hand strength to turn the gas key valve. Never use tools to turn the gas valve. If key valve will not turn by hand, do not try to repair it. Contact a qualified gas technician. Forcing or attempting to repair valve may cause fire or explosion.

1. Verify correct gas type (gas supply should match burner type.)
2. Verify correct pressure.
3. Purge gas lines of air, water and debris.
4. Perform all leak test with leak detector or leak reactant on main gas supply and repair leaks as necessary.
5. For 24V electronic ignition models have a qualified electrician install proper power supply following all local codes.
6. Shut off Gas Supply and Power to fire-pit.
7. Inspect flex line for punctures or breaks in lines.
8. Connect fire-pit to main gas supply. Avoid sharp bends with flex line to prevent whistling.
9. Position burner safely with access to all gas connections for testing.
10. Turn on gas supply and perform leak test on all connections and repair as needed. See detailed connection guide for your specific model.
11. Light burner.
12. For electronic ignition models, apply proper power supply. Electronic Ignition models can either be hard wired into main power supply or plugged into NEMA Rated, above grade, outdoor specific, GFCI outlet/receptacle. It is highly recommended that electrical supply be connected through on/off switch. No dimmers. Can be used in combination with remote controls.
13. Once fire pit is lit, perform leak test on all gas connections. Repair as needed.

14. Turn off fire pit and allow to cool.
15. Set burner into properly constructed enclosure.
16. Apply media as per installation instruction.
17. Complete final verification of correct operation and lighting.
18. Review safety manual with end user and instruct end user not to change/ modify fire pit or media in any way.
19. Leave manual with end user.

WARRANTY REQUIREMENT: Warranty is void if valve box for any/all electronic ignition system is opened or tampered with in any way. See warranty section for full warranty requirements.

MEDIA INSTALLATION

WARNING: Only use approved decorative media (glass, lava rock, ceramic log sets, etc.) that have been manufactured for specific use in fire features.

WARNING: Media must be 1/2" or larger in size to prevent media from falling into gas orifices and blocking flow of gas out of jets. Use approved media only.

WARNING: Burner and jets can be covered by 1/4" to 1/2" of media above jets. **PLEASE NOTE - covering over jets more than 1/4" to 1/2" may create back pressure and gas leakage through air cross holes resulting in pooling of gas under the fire feature which can result in explosion.** Also note that flame pattern will be affected by any media coverage over gas orifice jets up to and including smothering of flames.

WARNING: When using electronic ignition systems please pay particular attention to keeping media away from the pilot assembly area and/or away from wind screen of pilot assembly. Incorrect media installation that blocks pilot assembly will cause the pilot flame to suffocate, blocking of thermal sensor and/or a delay in main burner ignition.

WARNING: The fire pit is designed to use approved media that is correctly installed over the burner to achieve proper combustion. Use of any media outside of the approved media sold by Warming Trends may void warranty and effect proper operations.



Install enclosure and fire feature per instructions provided by manufacturer.



Apply media per instructions by pouring media around burner first, then pushing media towards the gas jet orifices making sure media does not fall into the gas jet orifices. Check each gas jet orifice prior to lighting to be sure no media has fallen into gas jet orifices.

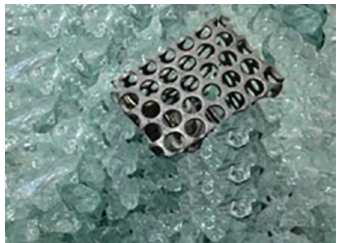

For All Electronic Ignition Systems: Keep pilot assembly screen free and clear of all media. Media should be piled no more than halfway up screen only (not over full amount of screen) so that pilot gas orifice opening is above media coverage allowing for pilot flame to easily reach gas jet orifice.



For Ceramic Log Sets: Place logs on top of lava rock base according to preference and desired flame pattern. For electronic ignition systems - do not block, cover or obstruct pilot assembly. Blocking, covering or placing ceramic logs too close to pilot may cause excessive heat on pilot causing system to fail. This is not covered under warranty.

FIRE FEATURE OPERATION

WARNING: If you do not follow these instructions exactly, a fire or explosion may result causing property damage, personal injury, or loss of life.

WARNING: Before use, be sure to test all gas connections for leaks. Do not use fire pit if there is any evidence of leaking gas. If leaking gas suspected, turn off the main gas supply and repair.

WARNING: If using an LP bottle, position at safe distance away from flame.

WARNING: Do not place LP bottle inside enclosure.

WARNING: Use only your hand to turn the gas key valve. Never use tools. If the key valve will not turn by hand, don't try to repair it. Call a qualified technician. Force or attempted repair may cause a fire or explosion.

WARNING: Wind and gusty conditions will affect the flame in an unpredictable manner. If conditions exist that are not safe for patrons - turn the fire pit off.

WARNING: Do not use fire pit if any part has been submerged under water. Immediately call a qualified service technician to inspect the fire pit.

WARNING: Never use any material for media that is non-porous and holds moisture such as gravel, pebbles, river rock, etc. This material, when heated will cause the trapped moisture to boil, fracture unexpectedly and/or explode and cause personal injury or damage.

WARNING: If lava rock is wet, allow fire pit to burn for 45 minutes prior to coming within 15 feet of the fire pit.

WARNING: Solid fuels shall not be burned in the fire pit. Leaves, sticks, wood, paper, clothing, food material, should be kept away from the fire pit. Make sure that there is no vegetation or other objects over the top or sides of the fire pit that could interfere with safe operation. If there is any questions as to clearances, refer to fire pit clearances in your owner's instructions manual for specific clearance allowances.

WARNING: When fire pit is not in operation turn off gas valve.

WARNING: For electronic ignition systems - power supply must be turned off to fire pit when not in operation.

WARRANTY REQUIREMENT: When not in use, fire feature must be covered at all times. Failure to cover the fire feature will void the warranty.

LIGHTING INSTRUCTIONS FOR:

Match Light / Manual Light (no electronics) / Push Button Ignition

1. STOP! Read all the safety information and warnings in the owner's manual before attempting to light fire feature.
1. Prior to turning appliance on visually inspect fire feature to ensure debris such as leaves or other combustible material has not collected inside the feature which could burn and emit embers once the fire feature is turned. Ensure no person is standing close to the fire feature.
2. Turn key valve clockwise slightly and then turn counterclockwise to the OFF position.
2. Wait (5) minutes to clear out any gas. Then smell for gas.
3. If you smell gas, STOP!
4. Shut off gas to appliance.
5. Extinguish any open flame.
6. If gas odor continues, keep away from appliance and immediately call gas supplier or fire department.
7. If you do not smell gas, turn key valve slowly counterclockwise to the ON position while igniting lighter simultaneously to ignite gas.
8. For Push Button: Press push button ignition and listen for clicking noise which indicates electrode is firing. Gas should ignite after a few clicks.

WARNING: If the flame will not stay lit after several tries, turn the key valve to the OFF position and call your service technician or gas supplier.

TO TURN OFF GAS APPLIANCE

1. Turn key valve clockwise until it stops.
2. Carefully verify flame is OUT.
3. If using LP bottle/tank - turn bottle/tank to CLOSED position
4. After allowing for ample cooling time, cover the fire feature with water proof / weather proof cover.

LIGHTING INSTRUCTIONS FOR: 3V Battery Operated System, 24V Premium Electronic Ignition System & 24V Standard Electronic Ignition System

1. STOP! Read all the safety information and warnings in the owner's manual before attempting to light fire feature.
2. Before operating appliance ensure the manual gas shutoff valve is open.
3. Prior to turning appliance on visually inspect fire feature to ensure debris such as leaves or other combustible material has not collected inside the feature which could burn and emit embers once the fire feature is turned. Ensure no person standing close to the fire feature.
4. Turn on fire feature with remote or power switch.

Sequence of Operation during Ignition

- Power is applied.
- For 24V Premium System - Hot Surface Igniter / Glow Plug becomes hot and 4 - 5 seconds later the Pilot Gas Valve opens.
- For 3 Volt Battery Operated System & 24V Standard System - Spark Igniter will spark repeatedly and 4 - 5 seconds later the Pilot Gas Valve will open.
- Within 10 seconds of power application Pilot Flame should be lighted and visible. (Visible at night only.)
- Within 10 seconds of Pilot Flame Ignition CROSSFIRE™ Brass Burner should ignite .

TO TURN OFF ELECTRONIC IGNITION GAS APPLIANCE

1. Turn off power to fire feature - which, in turn, will turn off fire feature - this can be done with remote control or switch.
2. Carefully verify flame is OUT.
3. Turn off key valve to cut gas off manually per Manual Light instructions.
4. If using LP bottle/tank - turn bottle/tank to CLOSED position
5. After allowing for ample cooling time, cover the fire feature with water proof / weather proof cover.

WARNING: If fire feature fails to turn off completely (small flames still visible), turn off gas supply using the manual gas shutoff.

MAINTENANCE

WARNING: Any guard or protective device removed for servicing must be replaced prior to operating the fire pit.

WARNING: Installation and repair should be done by a qualified technician. Fire pits should be inspected prior to each use and inspected at least once annually by a qualified gas appliance service professional.

WARNING: Ensure gas and power (if applicable) are shut off and fire pit is cool before servicing.

Keep fire pit covered at all times when not in use.

Keep any debris out of fire pit- clean as needed. If debris is found, remove before lighting system.

In some areas of the country, spiders or insects have been known to build nests and/ or lay eggs in the gas orifices at the bottom of the jets. This can cause fuel to fill the fire feature cavity and result in personal injury or property damage. Periodical inspection by a qualified service technician of the air-intake is required to ensure your fire feature performs properly.

CROSSFIRE™ Jet Orifice Cleaning: Once a year, if flames exhibit any abnormal shapes or behavior, or if burner fails to ignite properly, then the burner holes located in bottom of gas jet orifices may require cleaning. The appliance can be cleaned by carefully removing the logs and media to allow access to burner. Use a brush to carefully remove dust, spider webs and loose particles. Use a wire or puncture tool and carefully insert in jet. Tool should be size of a small paper clip. If evidence of damage, burner must be replaced with the appropriate CROSS-FIRE™ burner specified by manufacturer.

Thermocouple Cleaning of Soot: Every six months or as needed. Remove lava rock & glass around pilot, then the wind cage (screen around the pilot). Clean thermocouple of any soot using soft brush. Be careful not to damage the hot wire element. Place lava rock or glass back as explained in the Section Media Installation in Owners Installation Manual.

Visual inspection of pilot and pilot assembly: The pilot assembly should be free

and clear of any debris, dust, spider webs and loose particles from the media and logs. Once pilot assembly is clean, inspect to see flame that covers 3/8" to 1/2" of the thermocouple. Cleaning of pilot gas orifice may be required by removing pilot hood (CCW) and removing orifice and cleaning out orifices from debris, soot or anything that may be preventing good gas flow from exiting the pilot gas orifice.

Push Button Only: Visually inspect electrode and jet used for conductivity regularly to make sure it is free of debris and soot. Soot build up or obstructions of any kind can reduce effectiveness of spark. Without a strong spark, burner will not light. If spark is not strong enough, clean off / remove any soot from jet and, using fine grit sand paper, gently remove any rust from electrode. If spark is still not strong enough to light burner, check / replace batteries. If new batteries don't fix the problem, replace spark electrode. (See glossary for replacement part number.)

TROUBLESHOOTING - MANUAL LIT / PUSH BUTTON

Below are some potential causes and countermeasures to the symptoms listed:

No flame

- Make sure the key valve is on. Turn key counterclockwise to open valve and allow gas flow.

Low or Weak Flame

- Verify correct gas pressure.

One or more jets will not light.

- Check jets for obstruction.

Fire feature is making a whistling sound.

- Make sure that the flex line is the correct size and that there are no kinks in the line.

Contact a certified gas technician for service & repair if these suggestions do not solve the issue.

TROUBLESHOOTING - ELECTRONIC IGNITION SYSTEMS

Below are some potential causes and countermeasures to the symptoms below.

No Pilot Flame (Pilot sparks or glow plug glows but pilot won't light)

- Air is in the gas line. If this is a new install it may take several attempts to purge the air.
- Debris is in the gas line. Clear the gas line.
- Water/Moisture is in the gas line. Clear the gas line.
- Incorrect Gas pressure. Confirm proper gas pressure.
- Pilot gas orifice is dirty. Remove the pilot head and clean.
- Electrical current is not strong enough to support igniter - either spark on spark igniter isn't strong enough to ignite pilot flame (3V or Standard 24V) or glow plug is not getting hot enough to ignite pilot flame (Premium 24V).
- Improperly applied media.
- Wind conditions might be too severe.

No Main Burner (Pilot Lights but main burner will not light)

- Gas pressure is incorrect. Confirm proper gas pressure.
- Small pilot flame. Remove the pilot head and clean pilot gas orifice.
- Dirty thermal sensor. Clean using soft brush.
- CROSSFIRE™ BURNER has an obstruction. Confirm there is no debris blocking gas orifice jets in main burner, purge water and air from gas lines or in the burner, confirm there is no debris in gas lines.

Main Burner Turning On and Off Intermittently

- Small pilot flame. Remove the pilot head and clean orifice.
- Improperly applied media. See the Section "Media".
- Gas pressure is incorrect. Confirm proper gas pressure.
- Thermal sensor is dirty or defective. Clean thermal sensor. Or change the pilot assembly.
- Wind conditions might be too severe.

Fire Feature is Making a Whistling Sound

- Make sure that the flex line is the correct size and that there are no kinks or tight bends in the line.

If replacement parts are required - contact your authorized dealer for authorized replacement parts. Using unauthorized parts may cause damage to the unit and/or cause catastrophic failure of the unit. Warranty is null and void if unauthorized parts are used.

Please contact your retailer or certified technician for service & repair if these suggestions do not solve the issue.

WARRANTY

ALL BURNERS AND ELECTRONICS (IF PRESENT) MUST BE COVERED WHEN NOT IN USE OR WARRANTY IS NULL AND VOID

Warming Trends™ warrants its products to be free from defective material and workmanship under normal service and use. This warranty covers manufacturing defects only and does not cover defects due to normal wear and tear; it does not warrant any product or part that has been altered, accidentally damaged, damaged in shipping, disassembled, modified, misused, neglected, failure to maintain, not installed, or not kept in continuous service after installation. Warming Trends™ liability shall be restricted to the purchase price of the product only and makes no other warranty, express or implied, but not limited to, the implied warranties of salability and appropriateness for a specified purpose, with respect to its products and parts, whether used alone or in combination with others. Warming Trends™ is free of liability for any damages caused by the unit, as well as inconvenience expenses, material or labor charges incurred by any service call, repair, removal or re-installation of any unit. Incidental or consequential damages are not covered by this warranty. Warranty does not cover damage to systems due to debris in the gas lines or damage to system due to water. Owner is responsible for reading and understanding warranty for full terms and conditions

Warming Trends™, at its discretion, agrees to repair or replace defective product if returned to Warming Trends™ within the warranty period. The respective warranty time periods are effective from the original date of purchase. The warranty is non-transferable and applies only to the original purchaser. In addition, this warranty is automatically void if the unit's serial number has been removed or altered in any way.

Ignition Systems Warranty

ALL BURNERS AND ELECTRONICS MUST BE COVERED WHEN NOT IN USE OR WARRANTY IS NULL AND VOID

Push Button Ignition Systems

There is no warranty offered on any push button ignition system.

Electronic Ignition Systems

RESIDENTIAL INSTALLATIONS:

24VIK and 3VIK systems are fully warranted for one (1) year with a limited warranty for two (2) years from date of purchase. In the event a system must be replaced due to a defect/malfunction of the system, Warming Trends™ will repair or replace the system at no cost for the first year. In the event a system fails after the first year from date of purchase and within two years from date of purchase, Warming Trends™ will repair or replace the system for a cost of 50% of the current list price. This warranty does not cover labor costs.

P24VIK systems purchased ON OR BEFORE April 15, 2018 are fully warranted for one (1) year with a limited warranty for two (2) years from date of purchase. In the event a system must be replaced due to a defect/malfunction of the system, Warming Trends™ will repair or replace the system at no cost for the first year. In the event a system fails after the first year and within two years of date of purchase, the cost for a replacement system is at a discount rate of 50% of the current listed price. This warranty does not cover labor costs.

P24VIK Systems purchased AFTER April 15, 2018 are fully warranted for three (3) years from date of purchase. In the event a system must be replaced due to a defect/malfunction of the system, Warming Trends™ will repair or replace the system at no cost for the first three years. This warranty does not cover labor costs.

COMMERCIAL INSTALLATIONS:

24VIK and 3VIK systems are fully warranted for six (6) months from date of purchase. In the event a system must be replaced due to a defect/malfunction of the system, Warming Trends™ will repair or replace the system at no cost. This warranty does not cover labor costs.

P24VIK systems purchased ON OR BEFORE April 15, 2018 are fully warranted for six (6) months from date of purchase. In the event a system must be replaced due to a defect/malfunction of the system, Warming Trends™ will repair or replace the system at no cost. This warranty does not cover labor costs.

P24VIK Systems purchased AFTER April 15, 2018 are fully warranted for one (1) year from date of purchase. In the event a system must be replaced due to a defect/malfunction of the system, Warming Trends™ will repair or replace the system at no cost for 12 months from the date of purchase. This warranty does not cover labor costs.

Problems in the functioning of the systems due to gas plumbing or electrical installed by others are not covered by any warranty offered by Warming Trends.



No dealer, distributor, or other person has the authority to represent or warrant a Warming Trends™ product beyond the terms contained within this warranty, and Warming Trends™ assumes no liability for such warranty representations. Any questions concerning this warranty should be directed to the Warming Trends™ corporate office.

Return Policy of Warranty Product

Any Warming Trends™ product deemed by Warming Trends™ as defective and covered by the warranty may be returned to Warming Trends™ for assessment to determine if repair or replacement is necessary. In order to return a product, you must have a Return Merchandise Authorization number (RMA#). Please contact a Warming Trends™ representative at the corporate office to obtain an RMA#. All returned merchandise must have the RMA# clearly printed on the outside of the package. Return shipping costs are the purchaser's responsibility. Warming Trends™ is not responsible for product damaged or lost in transit. It is recommended that return items are shipped via a delivery service that can be tracked and/or insured to confirm receipt.

EXAMPLE OF SERIAL NUMBER LABELS (Example only - actual label may vary)

Certified

Warming Trends ~ 4731 S Santa Fe Cir #2, Englewood, CO 80110		
Model No: CFB60LP		
Serial No: 120516LP203675		
<input type="checkbox"/> Input: 60,000 BTU/HR	<input type="checkbox"/> Input: 65,000 BTU/HR	<input type="checkbox"/> Input: 120,000 BTU/HR
<input type="checkbox"/> Input: 180,000 BTU/HR	<input type="checkbox"/> Input: 250,000 BTU/HR	<input type="checkbox"/> Input: 350,000 BTU/HR
<input type="checkbox"/> LP Min-Max Gas Supply: 11"-13" W.C.	<input type="checkbox"/> NG Min-Max Gas Supply: 4.5"-11.5" W.C.	
<input type="checkbox"/> LP Min-Max Gas Supply: 8"-14" W.C.	<input type="checkbox"/> NG Min-Max Gas Supply: 3.5"-14" W.C.	
<input type="checkbox"/> LP Min-Max Gas Supply: 8"-12" W.C.	<input type="checkbox"/> NG Min-Max Gas Supply: 4.5"-10" W.C.	
<input type="checkbox"/> LP Min-Max Gas Supply: 11"-13" W.C.	<input type="checkbox"/> NG Min-Max Gas Supply: 4.5"-10" W.C.	
<small>For Outdoor Use Only. For Installation with CROSSFIRE Brass Burners Only. If Stored Indoors, Detach and Leave Cylinder Outdoors. Minimum Clearance 36" From Any Wall and 120" From Ceiling (From Top Of Log)</small>		
		<small>Compliance with the Following Codes: 2015, 2012, and 2009 International Fire Code® (IFC) 2015, 2012, and 2009 International Fuel Gas Code® (IFGC) 2012 and 2009 Uniform Mechanical Code® (UMC) 2010 National Gas and Propane Installation Code Compliance with the Following Standards: ANSI Z21.97/CSA 2.41-2014 Outdoor Decorative Gas Appliance</small>
<small>Manufacturer of the CROSSFIRE™ Brass Burner</small>		

Non-Certified

Warming Trends ~ 4731 S Santa Fe Cir #2, Englewood, CO 80110		
Model No: CFB60LP		
Serial No: 120516LP203675		
<input type="checkbox"/> Input: 60,000 BTU/HR	<input type="checkbox"/> Input: 65,000 BTU/HR	<input type="checkbox"/> Input: 120,000 BTU/HR
<input type="checkbox"/> Input: 180,000 BTU/HR	<input type="checkbox"/> Input: 250,000 BTU/HR	<input type="checkbox"/> Input: 350,000 BTU/HR
<input type="checkbox"/> LP Min-Max Gas Supply: 11"-13" W.C.	<input type="checkbox"/> NG Min-Max Gas Supply: 4.5"-11.5" W.C.	
<input type="checkbox"/> LP Min-Max Gas Supply: 8"-14" W.C.	<input type="checkbox"/> NG Min-Max Gas Supply: 3.5"-14" W.C.	
<input type="checkbox"/> LP Min-Max Gas Supply: 8"-12" W.C.	<input type="checkbox"/> NG Min-Max Gas Supply: 4.5"-10" W.C.	
<input type="checkbox"/> LP Min-Max Gas Supply: 11"-13" W.C.	<input type="checkbox"/> NG Min-Max Gas Supply: 4.5"-10" W.C.	
<small>For Outdoor Use Only. For Installation with CROSSFIRE Brass Burners Only. If Stored Indoors, Detach and Leave Cylinder Outdoors. Minimum Clearance 36" From Any Wall and 120" From Ceiling (From Top Of Log)</small>		
		<small>Compliance with the Following Codes: 2015, 2012, and 2009 International Fire Code® (IFC) 2015, 2012, and 2009 International Fuel Gas Code® (IFGC) 2012 and 2009 Uniform Mechanical Code® (UMC) 2010 National Gas and Propane Installation Code Compliance with the Following Standards: ANSI Z21.97/CSA 2.41-2014 Outdoor Decorative Gas Appliance</small>
<small>Manufacturer of the CROSSFIRE™ Brass Burner</small>		

CROSSFIRE™

B R A S S B U R N E R S

Manufactured by
WarmingTrends™

- Select key valve location on your fire pit.
- Plumb your existing gas supply into one side of your key valve.
- Position your preferred support materials for the burner & plate inside of your fire pit (i.e., cinder blocks, elbow brackets, etc.)
- Warming Trends recommends a 4" clearance from the finished top of your fire pit (capstones) to your plate.
- For Match Lit burners, Warming Trends™ recommends a minimum 6" clearance below plate for additional connections.
- For Electronic Ignition burners, Warming Trends™ recommends a minimum of 16" - 20" clearance below plate for additional connections.
- Use thread sealant that is resistant to all gases on all fittings except flared fitting to flex line connections.
- Be sure to tighten every joint securely. Use thread sealant where required.
- Perform leak tests on all fittings before turning on ignition.

WARNING: Minimum requirement: Incorporate 1 vent on at least two opposing sides (2 vents total) at a minimum size of 18 sq. inches each (Example: 3"x 6" or larger). Installation of the vents in the mid to lower area of the enclosure is recommended. Ventilation allows for heat and/or residual fuel to escape. Failure to properly vent enclosure may result in the fire pit overheating or explosion. Overheating could lead to heat damage to internal components. Some enclosures may require more ventilation based on material, size, and extended use. The vent may serve as a drain as well when installed at bottom sidewall to prevent water build up. Always consult with local municipality regarding any local code requirements.

WARNING: Ready-to-Finish Kits come with Fire Pit Vent Kit (FPVK). Vents do not come pre-installed on Ready-to-Finish Kit as placement and installation depends on veneer. Vents to be installed by contractor on site.

60K - 120K BTU System with ½" Flex Line (FLKV12)

Original Series: CFB60, CFB84, CFB120 | Linear Series: CFBL90, CFBL110 | H-Style Series: CFBH120
Any custom burners between 60K - 120K

FOR PUSH BUTTON IGNITION INSTRUCTIONS: Follow Match Lit System installation instructions. When finished, turn to page 26 for Push Button Ignition installation instructions.

STEP 1: Locate FLKV12

Parts include ½" flex line, key valve and keys (4 and 12 inch.)

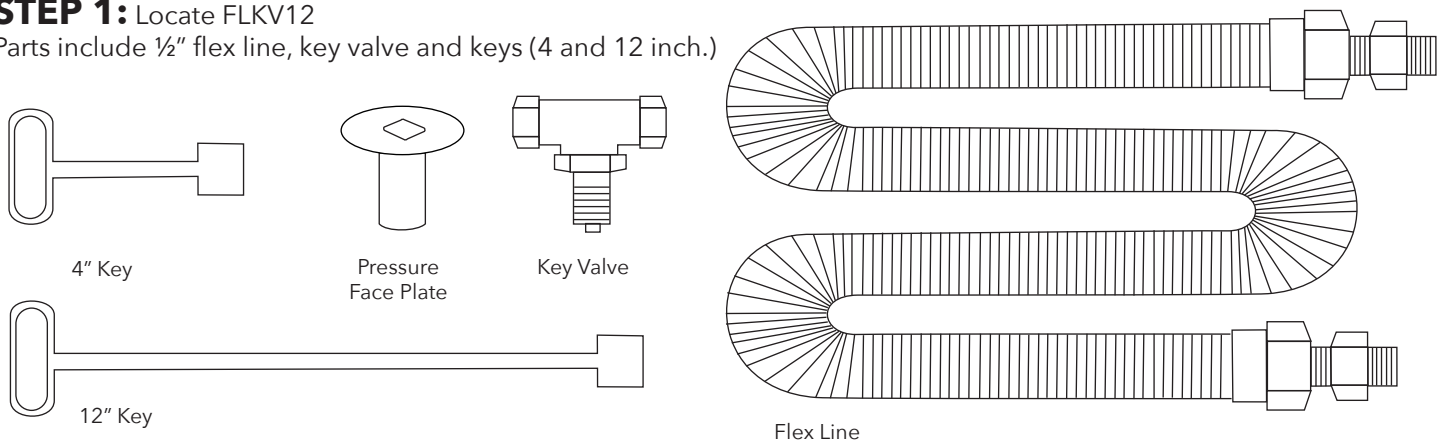

STEP 2: Remove 1/2" flared fittings from each end of 1/2" flex line.

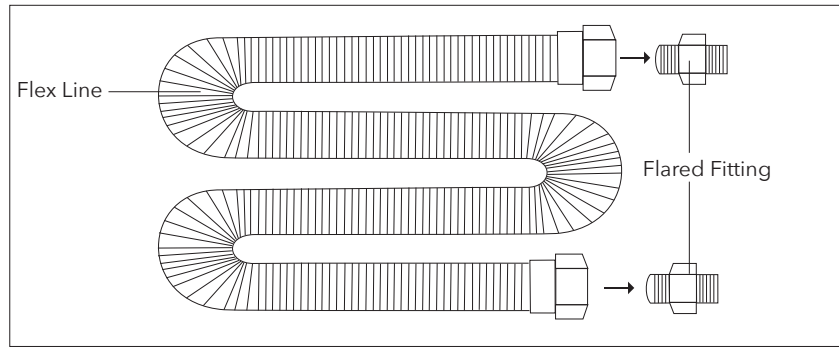

STEP 3A: (FOR MATCH LIT SYSTEM)

Connect one of your 1/2" flared fittings removed in Step 2 to the 1/2" coupling located on the bottom of the aluminum plate with flared end on bottom. Tighten.

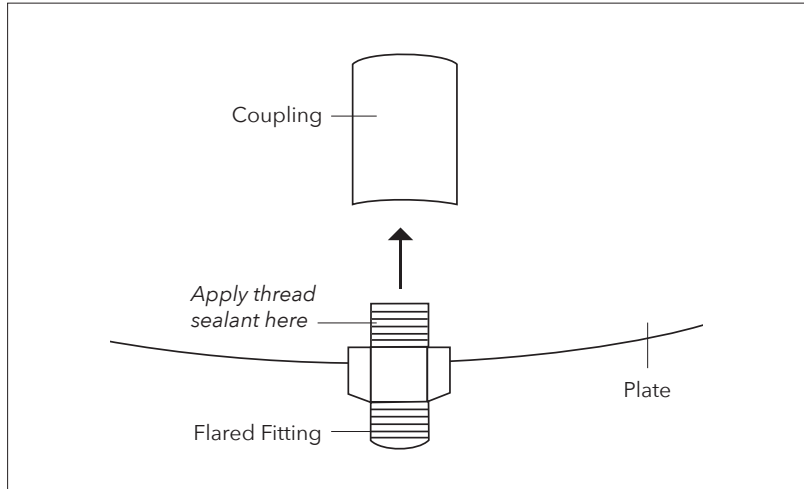

STEP 3B: (3 VOLT IGNITION)

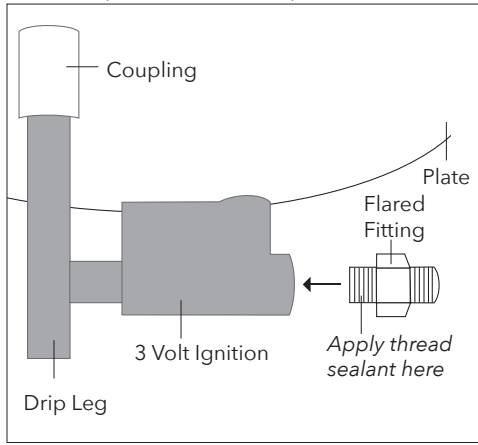

STEP 3C: (STANDARD 24 VOLT IGNITION)

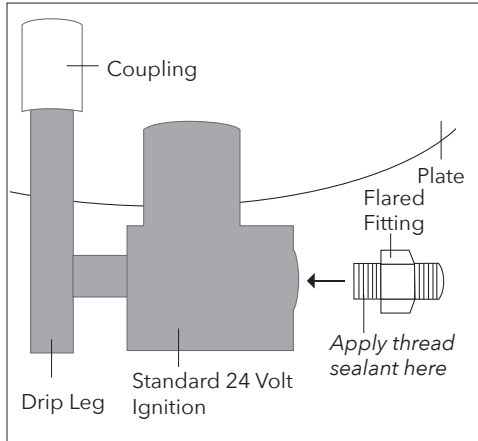

STEP 3D: (PREMIUM 24 VOLT IGNITION)

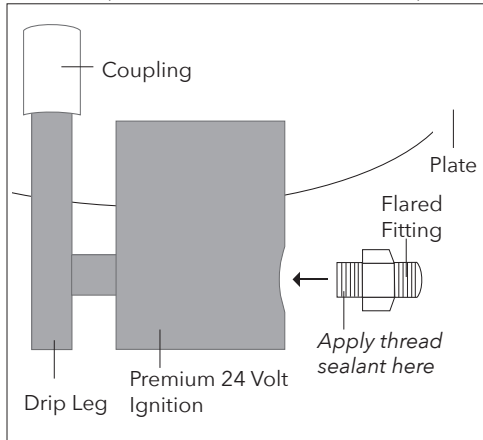

STEP 4A: (MATCH LIT SYSTEM)

Connect the 1/2" flex line to the fitting now located on the bottom of your aluminum plate.

STEP 4B: (3 VOLT IGNITION)

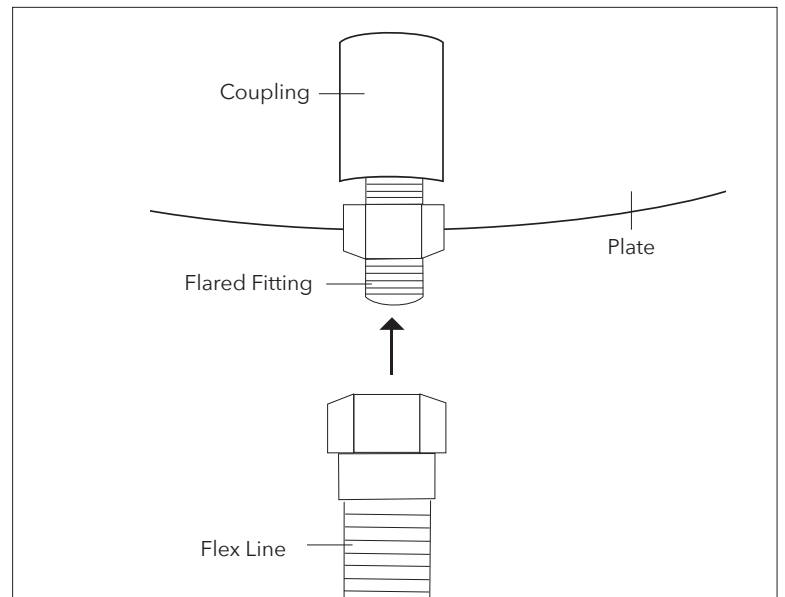
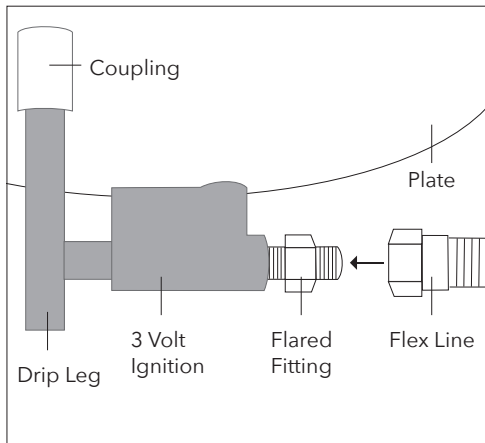

STEP 4C: (STANDARD 24 VOLT IGNITION)

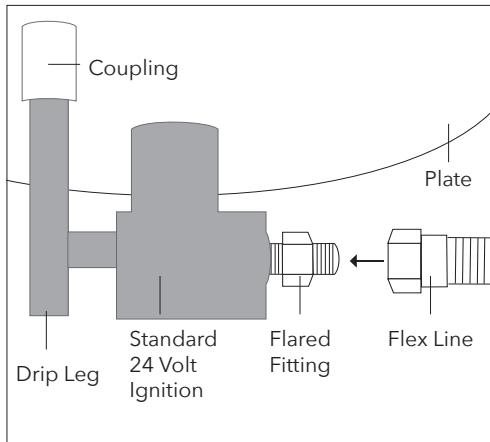

STEP 4D: (PREMIUM 24 VOLT IGNITION)

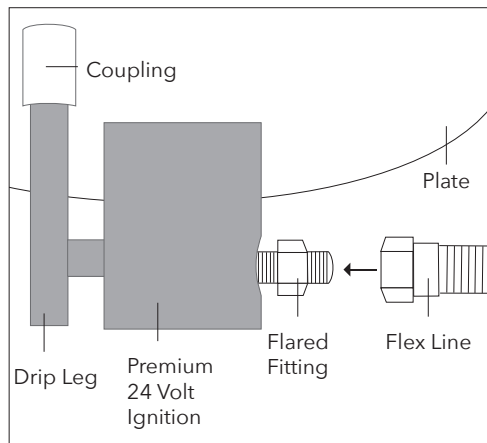

STEP 5: Locate the other 1/2" flared fitting removed in Step 2 and connect into the 1/2" key valve, placing the non-flared end into the key valve. Tighten..

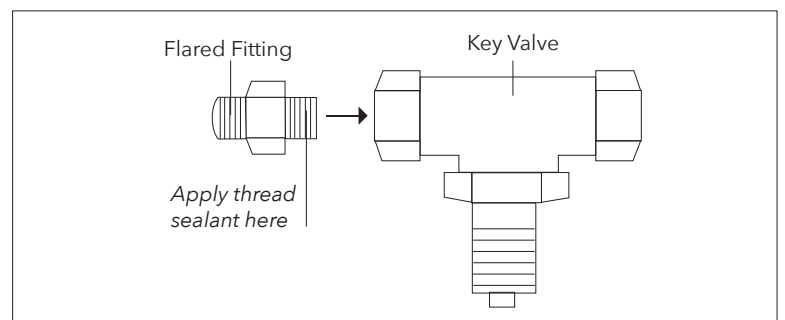

FINAL SET UP

STEP 6A: (MATCH LIT SYSTEM) Connect 1/2" flex line into the fitting connected in Step 5 to key valve. Tighten.

STEP 6B: (3 VOLT IGNITION)

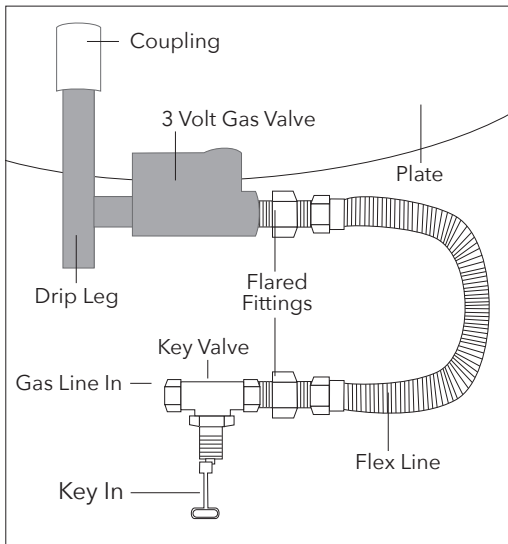

STEP 6C: (STANDARD 24 VOLT IGNITION)

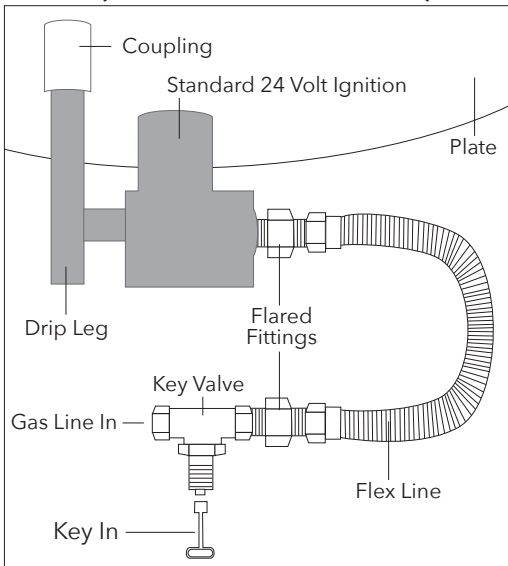

STEP 6D: (PREMIUM 24 VOLT IGNITION)

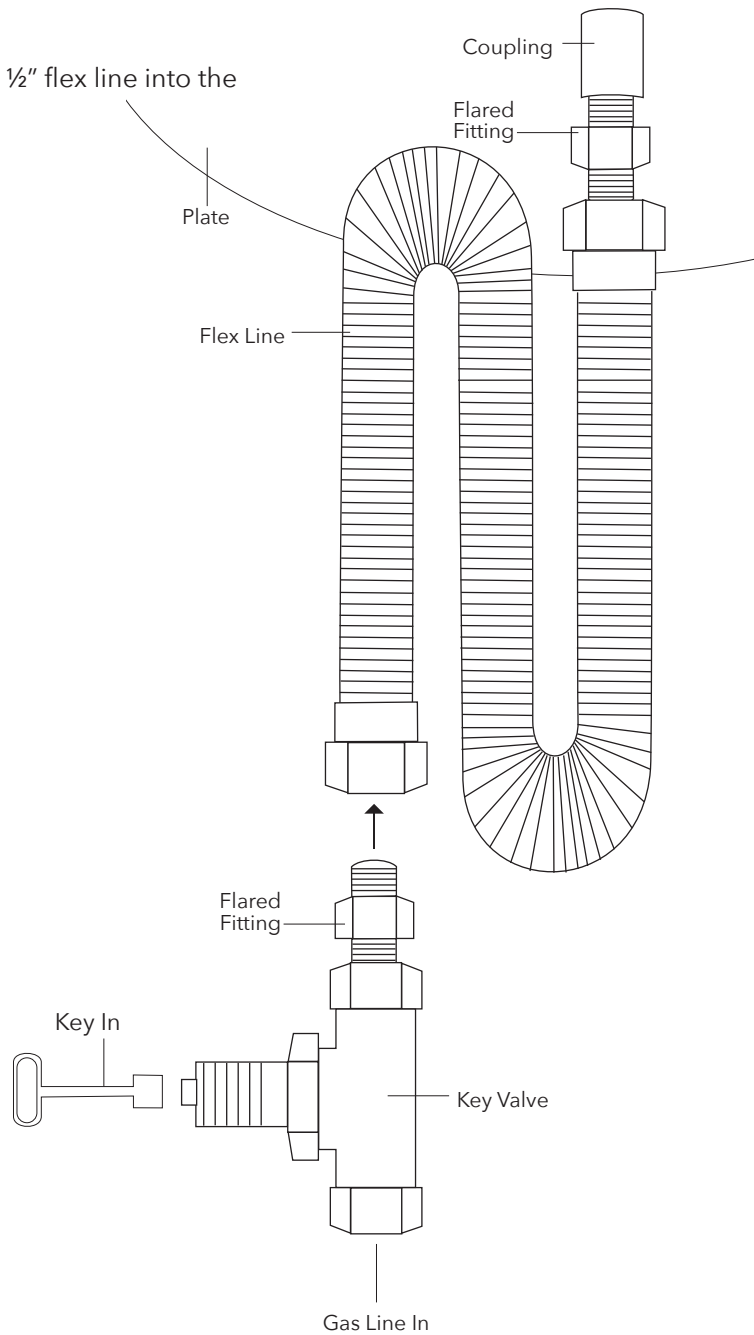
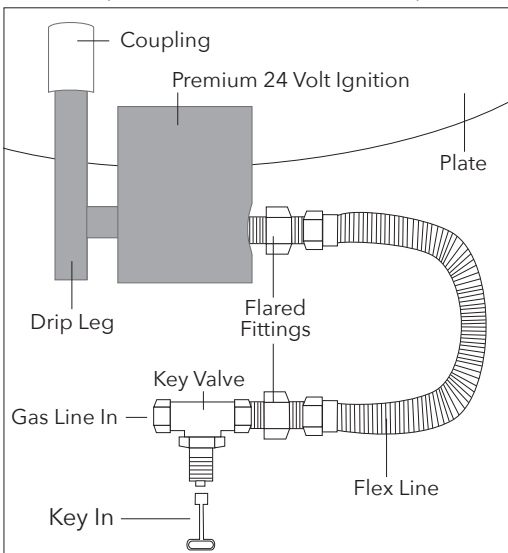

STEP 7: (STANDARD 24 VOLT AND PREMIUM 24 VOLT IGNITION SYSTEMS ONLY)

Plug ignition into three prong, above grade, NEMA Rated, outdoor specific GFCI electrical outlet or have electrician hardwire ignition into transformer.

WARNING: Minimum requirement: Incorporate 1 vent on at least two opposing sides (2 vents total) at a minimum size of 18 sq. inches each (Example: 3"x 6" or larger). Installation of the vents in the mid to lower area of the enclosure is recommended. Ventilation allows for heat and/or residual fuel to escape. Failure to properly vent enclosure may result in the fire pit overheating or explosion. Overheating could lead to heat damage to internal components. Some enclosures may require more ventilation based on material, size, and extended use. The vent may serve as a drain as well when installed at bottom sidewall to prevent water build up. Always consult with local municipality regarding any local code requirements.

WARNING: Ready-to-Finish Kits come with Fire Pit Vent Kit (FPVK). Vents do not come pre-installed on Ready-to-Finish Kit as placement and installation depends on veneer. Vents to be installed by contractor on site.

121K - 249K BTU Systems with 3/4" Flex Line (FLKV34) or 3/4" Flex Line + FIT180 (FLKV34FIT180)

Original Series: CFB180 | Linear Series: CFBL130, CFBL150, CFBL190, CFBL210 | H-Style Series: CFBH160, CFBH200, CFBH240 Any custom burners between 121K - 249K

FOR PUSH BUTTON IGNITION INSTRUCTIONS: Follow Match Lit System installation instructions. When finished, turn to page 26 for Push Button Ignition installation instructions.

STEP 1: Locate FLKV34

Parts include 3/4" flex line, key valve and keys (4 and 12 inch) and FIT180.

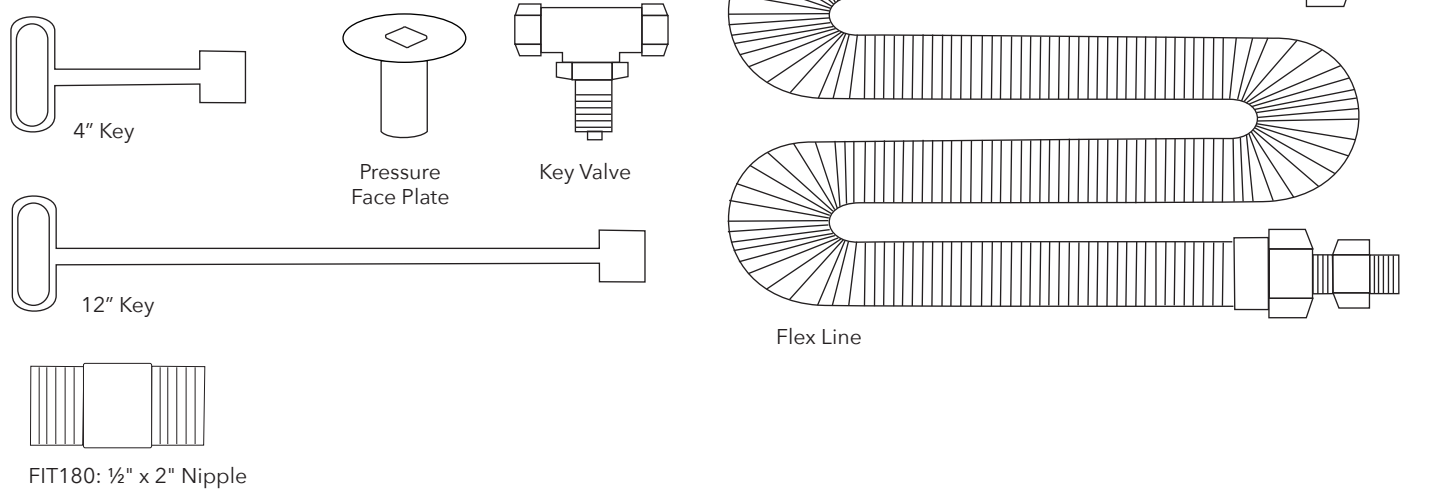

STEP 2: Remove 3/4" flared fittings from each end of 3/4" flex line.

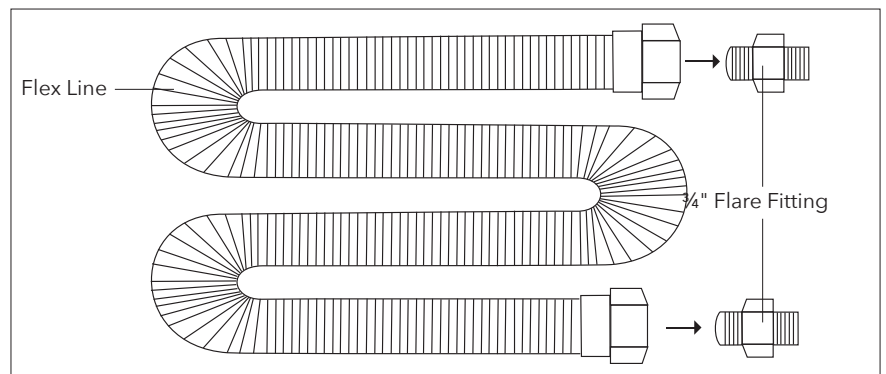

STEP 3: Connect your FIT180 fitting to the **inside threads** of one of the 3/4" flared fittings removed in Step 3.

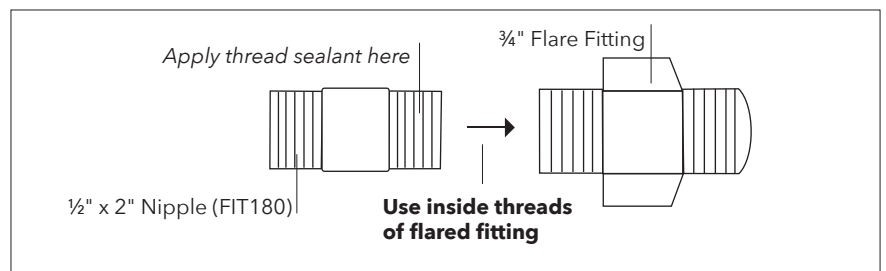

STEP 4A: (MATCH LIT SYSTEM) Connect the new fitting created in Step 4 to the 1/2" coupling located on the bottom of the aluminum plate. Tighten.

STEP 4B: (STANDARD 24 VOLT IGNITION)

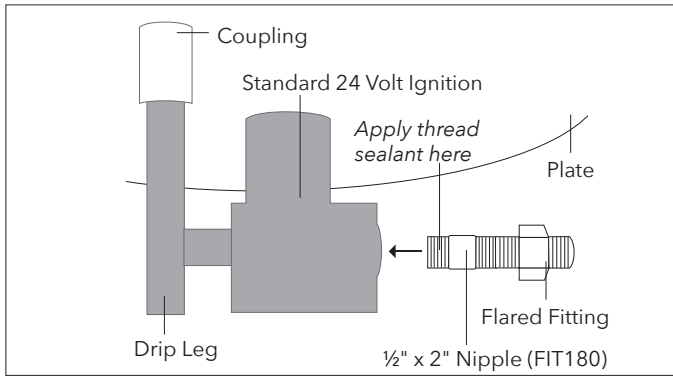

STEP 4C: (PREMIUM 24 VOLT IGNITION)

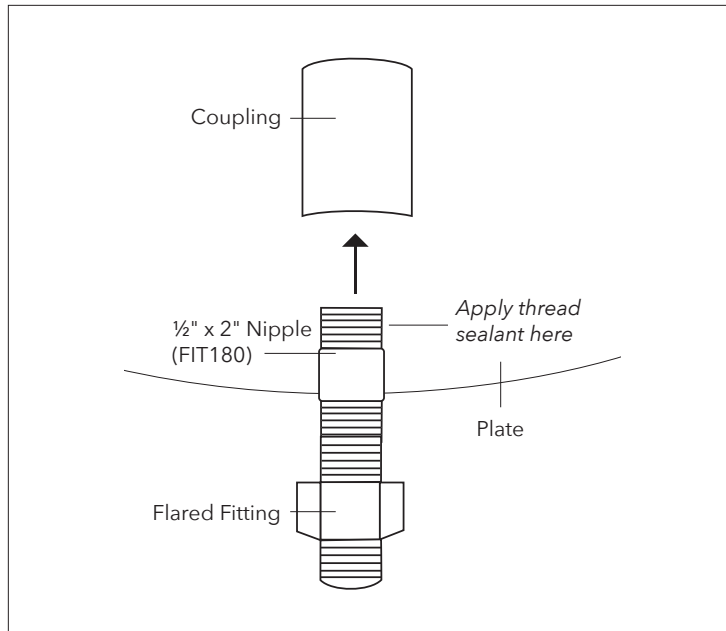
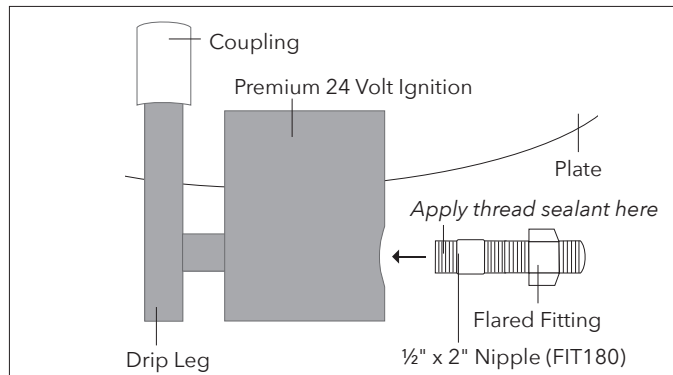

STEP 5A: (MATCH LIT SYSTEM) Connect 3/4" flex line to the fitting now located on the bottom of the aluminum plate.

STEP 5B: (STANDARD 24 VOLT IGNITION)

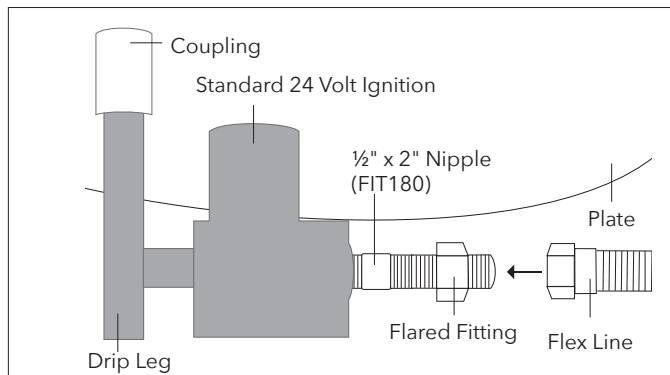

STEP 5C: (PREMIUM 24 VOLT IGNITION)

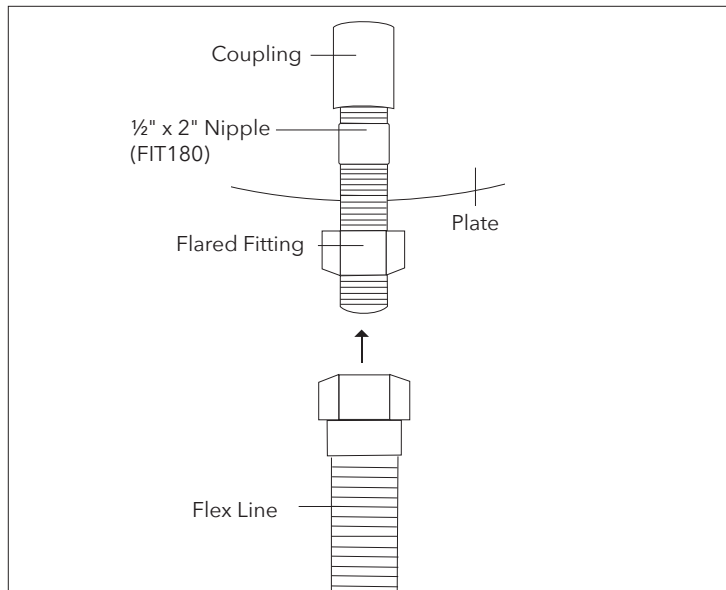
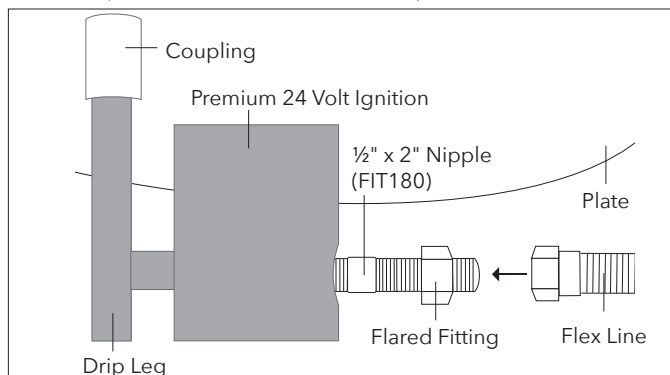

STEP 6: Locate the other 3/4" flared fitting removed in Step 3 and connect into the 3/4" key valve. Tighten using crescent wrench.

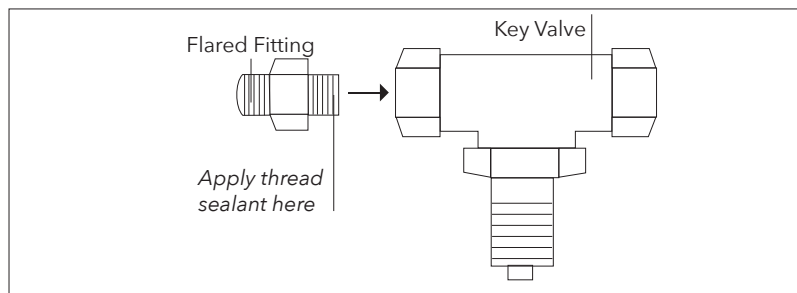

FINAL SET UP

STEP 7A: MATCH LIT SYSTEM Connect 3/4" flex line into the fitting connected in Step 7. Tighten.

STEP 7B: (STANDARD 24 VOLT IGNITION)

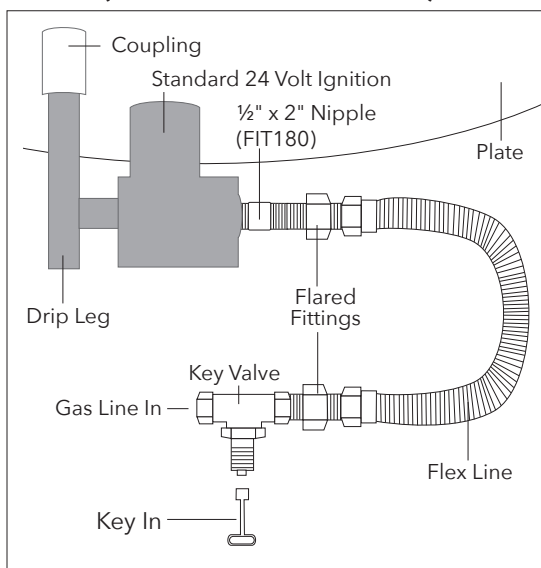

STEP 7C: (PREMIUM 24 VOLT IGNITION)

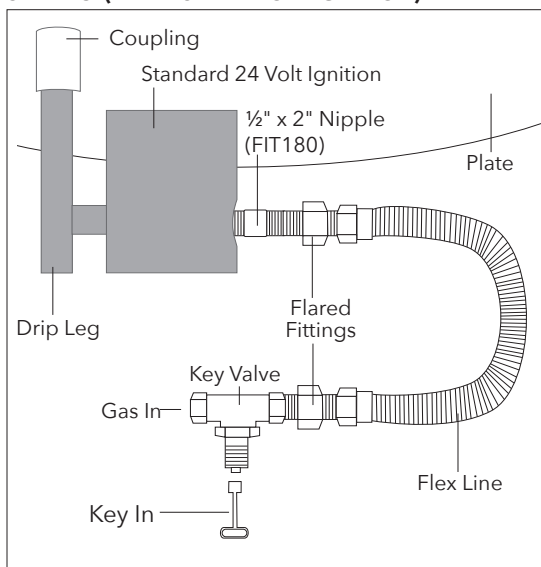

STEP 8: (STANDARD 24 VOLT AND PREMIUM 24 VOLT IGNITION SYSTEMS ONLY)

Plug ignition into three prong, above grade, NEMA Rated, outdoor specific GFCI electrical outlet or have electrician hardwire ignition into transformer.

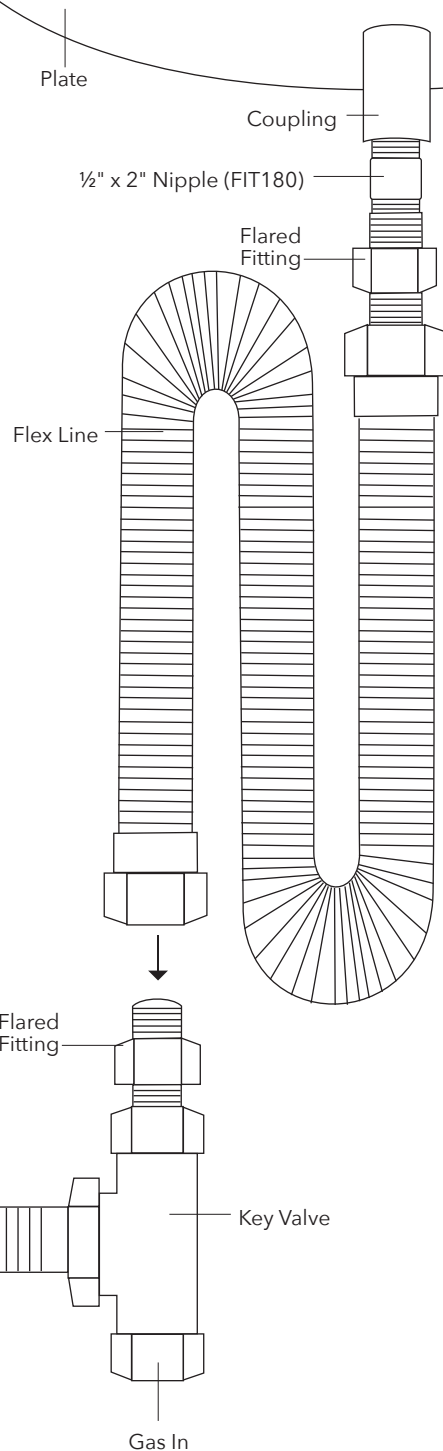

WARNING: Minimum requirement: Incorporate 1 vent on at least two opposing sides (2 vents total) at a minimum size of 18 sq. inches each (Example: 3"x 6" or larger). Installation of the vents in the mid to lower area of the enclosure is recommended. Ventilation allows for heat and/or residual fuel to escape. Failure to properly vent enclosure may result in the fire pit overheating or explosion. Overheating could lead to heat damage to internal components. Some enclosures may require more ventilation based on material, size, and extended use. The vent may serve as a drain as well when installed at bottom sidewall to prevent water build up. Always consult with local municipality regarding any local code requirements.

WARNING: Ready-to-Finish Kits come with Fire Pit Vent Kit (FPVK). Vents do not come pre-installed on Ready-to-Finish Kit as placement and installation depends on veneer. Vents to be installed by contractor on site.

250K - 299K BTU Match Lit System with 3/4" Dual Flex Lines (DFLKV34) or 3/4" Dual Flex Lines + FIT250 (DFLKV34FIT250)

Original Series: CFB250, CFB290 | Linear Series: CFBL250, CFBL270
Any custom burners between 250K - 299K

NOTE: If using the Standard 24 Volt High Capacity Ignition, turn to page 25 for instruction on installation. Burners between 250K - 300K BTU's using a Standard 24 Volt Ignition will need to use the FIT300. Turn to page 20 for installation instructions.

FOR PUSH BUTTON IGNITION INSTRUCTIONS: Follow Match Lit System installation instructions. When finished, turn to page 26 for Push Button Ignition installation instructions.

STEP 1: Locate DFLKV34 and FIT250

Parts include two 3/4" flex lines, key valve and keys (4" and 12") plus FIT250 Kit.

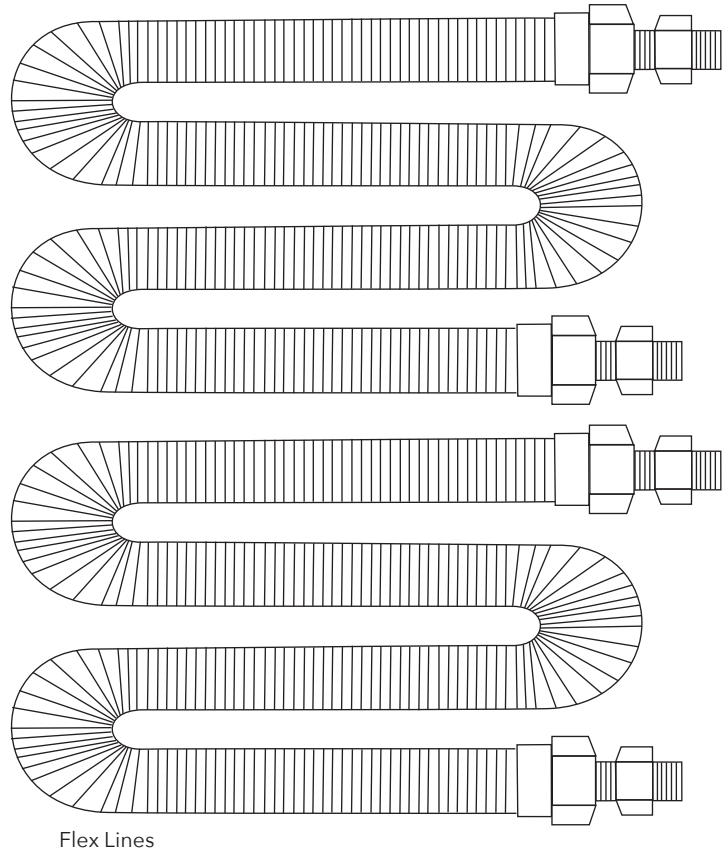
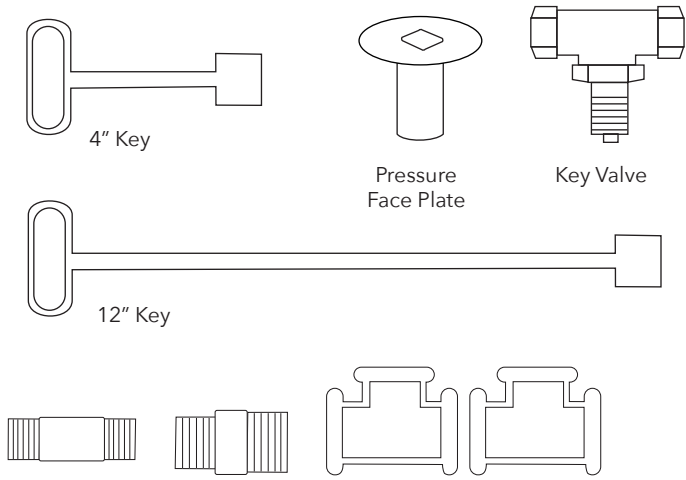

STEP 2: Remove $\frac{3}{4}$ " flared fittings from each end of $\frac{3}{4}$ " flex lines.

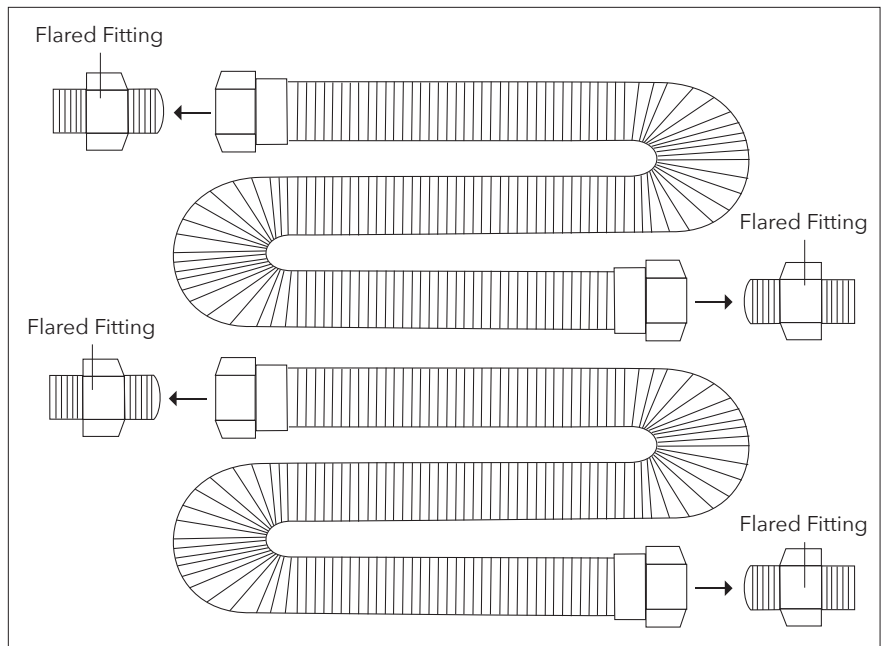

STEP 3A: Connect $\frac{1}{2}$ " x $\frac{3}{4}$ " reducing fitting to the $\frac{1}{2}$ " coupling located underneath the aluminum plate.

STEP 3B: (STANDARD 24 VOLT HIGH CAPACITY IGNITION)

SEE PAGE 20 FOR
INSTALLATION
INSTRUCTION

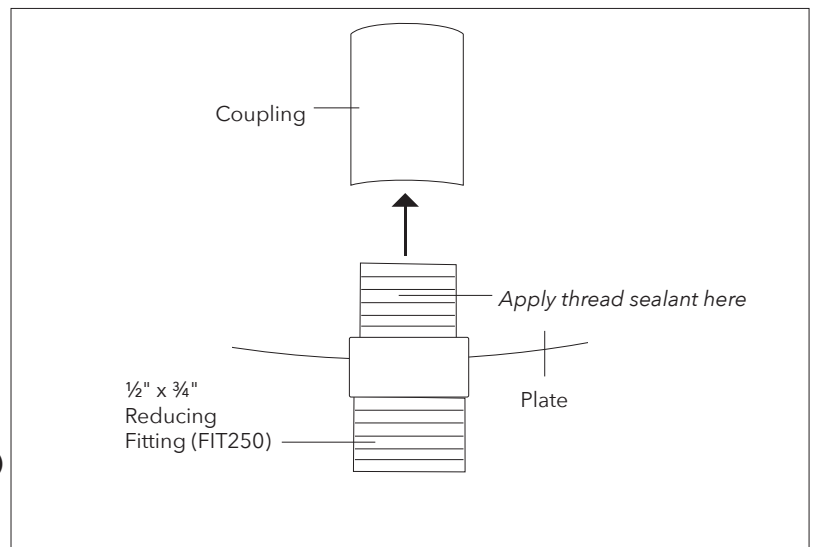

STEP 3C: (PREMIUM 24 VOLT STANDARD CAPACITY IGNITION)

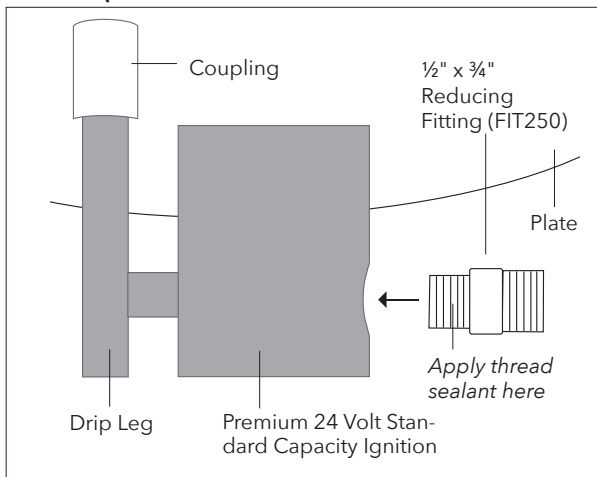

STEP 4A: Connect one 3/4" tee fitting to the connection made in Step 3 (1/2" x 3/4" reducing fitting under aluminum pan.)

STEP 4B: (STANDARD 24 VOLT HIGH CAPACITY IGNITION)

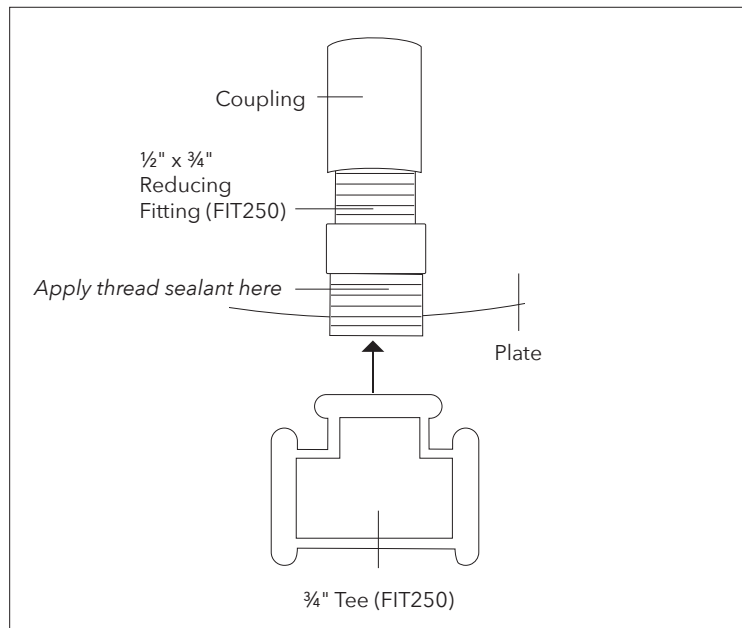
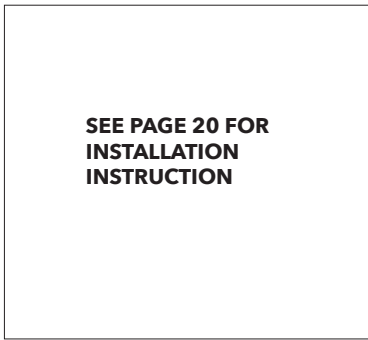

STEP 4C: (PREMIUM 24 VOLT STANDARD CAPACITY IGNITION)

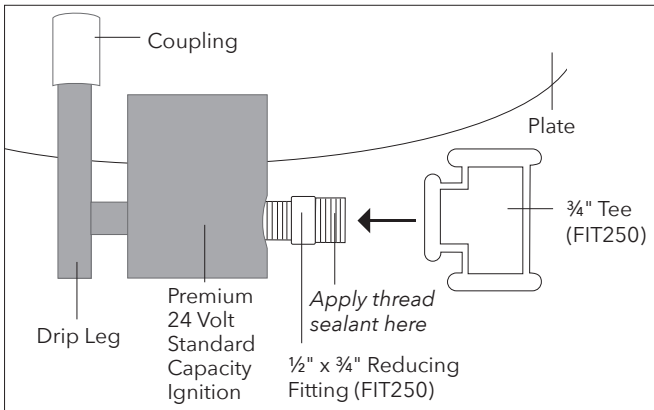

STEP 5A: Connect two of the 3/4" flared fittings removed in Step 2 to tee fitting now located underneath aluminum plate.

STEP 5B: (STANDARD 24 VOLT HIGH CAPACITY IGNITION)

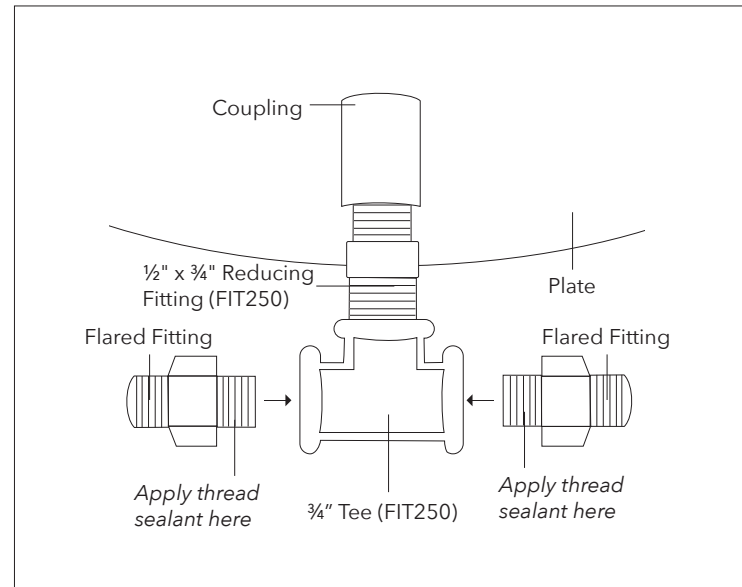

STEP 5C: (PREMIUM 24 VOLT STANDARD CAPACITY IGNITION)

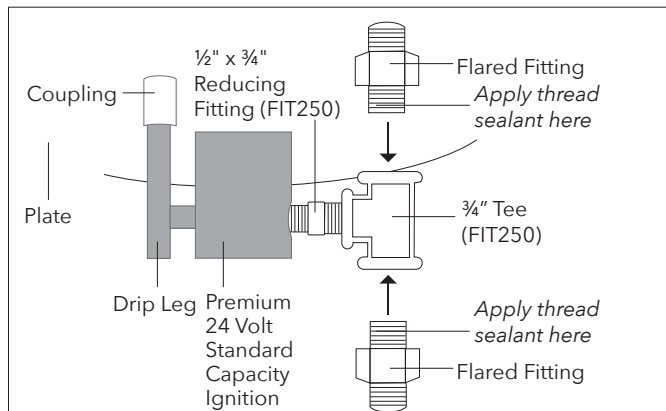

STEP 6A: Connect both $\frac{3}{4}$ " flex lines to the $\frac{3}{4}$ " flared fittings connected in Step 5. Tighten.

STEP 6B: (STANDARD 24 VOLT HIGH CAPACITY IGNITION)

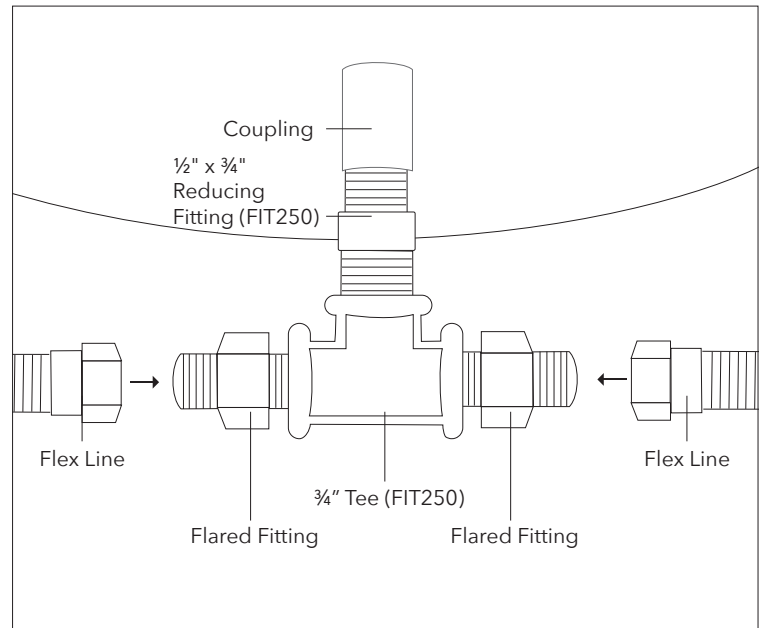
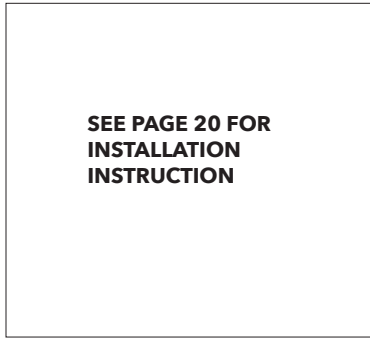

STEP 6C: (PREMIUM 24 VOLT STANDARD CAPACITY IGNITION)

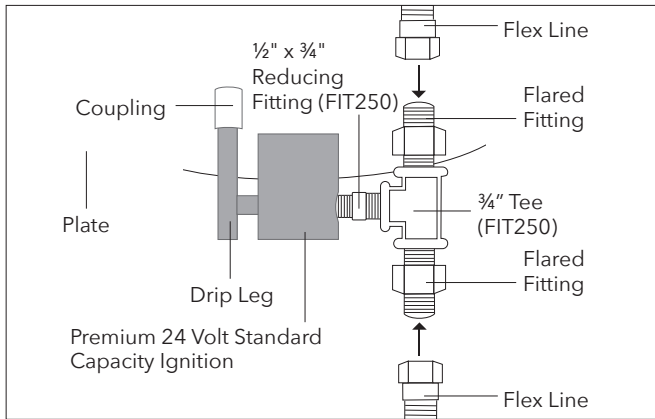

STEP 7A: Connect $\frac{3}{4}$ " x 3" pipe nipple (FIT250) to the $\frac{3}{4}$ " key valve.

STEP 7B: (STANDARD 24 VOLT IGNITION)
Same as above.

STEP 7C: (PREMIUM 24 VOLT IGNITION)
Same as above.

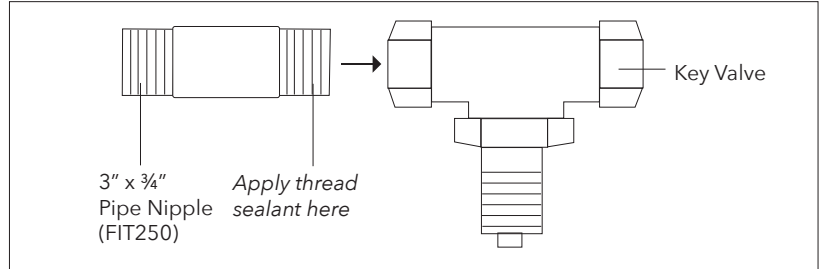

STEP 8: Connect remaining $\frac{3}{4}$ " tee fitting (FIT250) to the connection made in Step 7.

STEP 8B: (STANDARD 24 VOLT IGNITION)
Same as above using FIT300.

STEP 8C: (PREMIUM 24 VOLT IGNITION)
Same as above using FIT250.

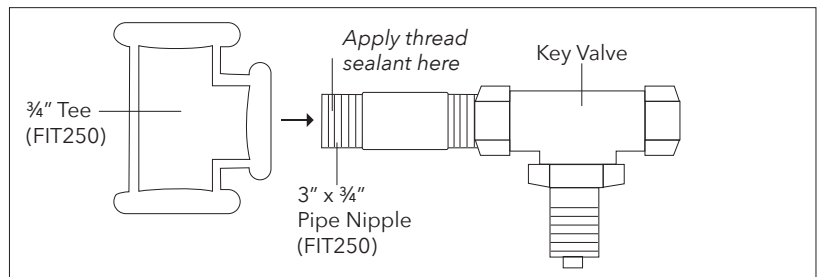

STEP 9: Connect remaining $\frac{3}{4}$ " flared fittings to the $\frac{3}{4}$ " tee fitting connection made in Step 8.

STEP 9B: (STANDARD 24 VOLT IGNITION)
Same as above.

STEP 9C: (PREMIUM 24 VOLT IGNITION)
Same as above.

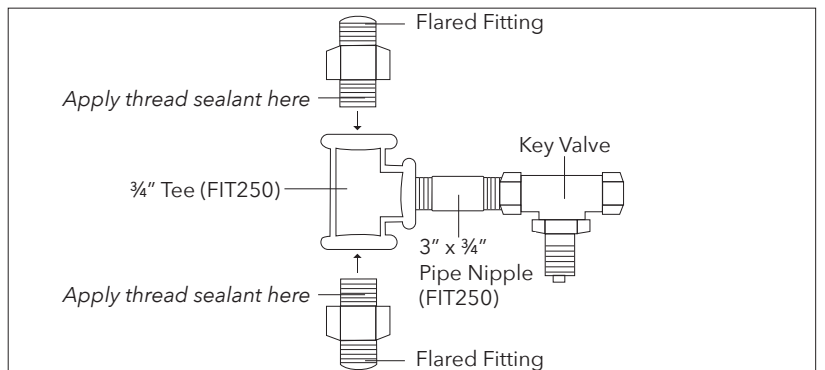

FINAL SET UP

STEP 10A: Connect available ends of 3/4" flex lines (connected to aluminum plate in Step 6) to 3/4" flared fittings connected in Step 10.

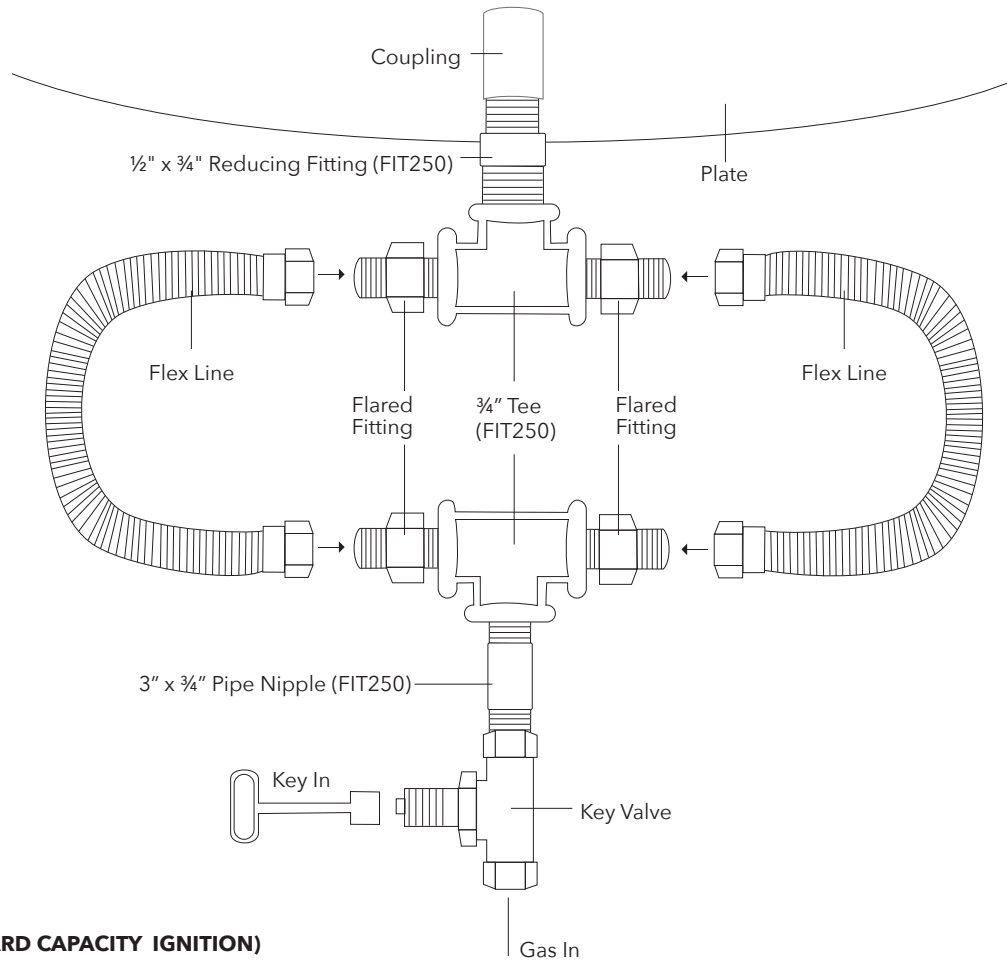

STEP 10B: (STANDARD 24 VOLT HIGH CAPACITY IGNITION)

SEE PAGE 20 FOR
INSTALLATION
INSTRUCTION

STEP 10C: (PREMIUM 24 VOLT STANDARD CAPACITY IGNITION)

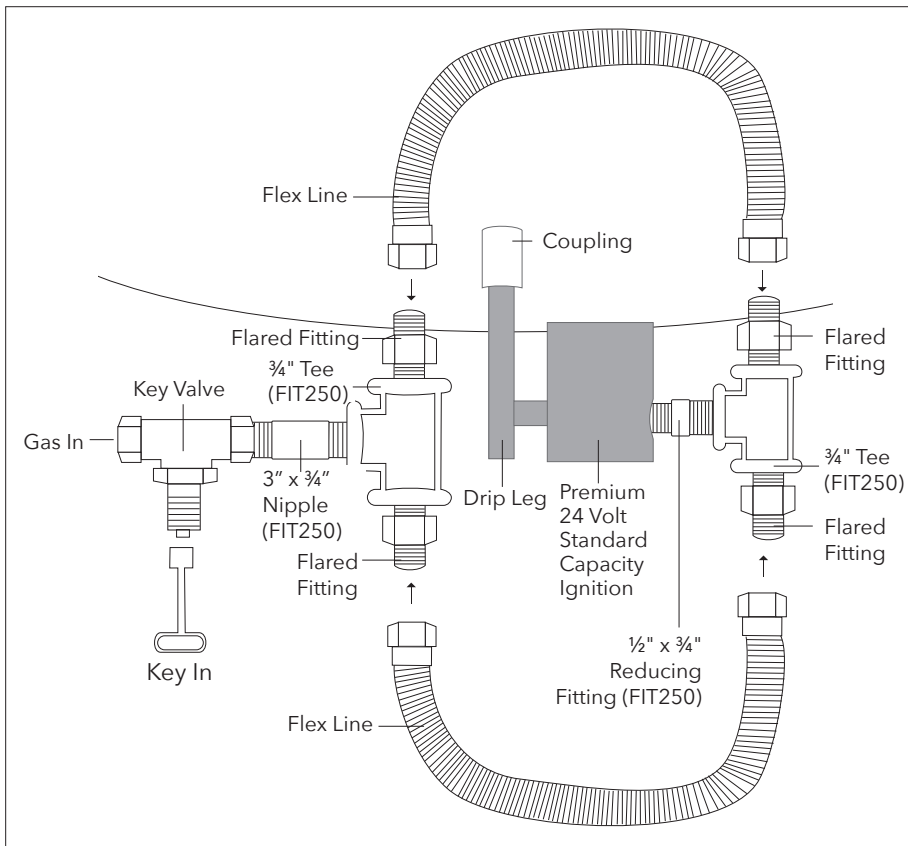

STEP 11: (STANDARD 24 VOLT AND PREMIUM 24 VOLT IGNITION SYSTEMS ONLY)

Plug ignition into three prong, above grade, NEMA Rated, outdoor specific GFCI electrical outlet or have electrician hardwire ignition into transformer.

WARNING: Minimum requirement: Incorporate 1 vent on at least two opposing sides (2 vents total) at a minimum size of 18 sq. inches each (Example: 3"x 6" or larger). Installation of the vents in the mid to lower area of the enclosure is recommended. Ventilation allows for heat and/or residual fuel to escape. Failure to properly vent enclosure may result in the fire pit overheating or explosion. Overheating could lead to heat damage to internal components. Some enclosures may require more ventilation based on material, size, and extended use. The vent may serve as a drain as well when installed at bottom sidewall to prevent water build up. Always consult with local municipality regarding any local code requirements.

WARNING: Ready-to-Finish Kits come with Fire Pit Vent Kit (FPVK). Vents do not come pre-installed on Ready-to-Finish Kit as placement and installation depends on veneer. Vents to be installed by contractor on site.

300K+ BTU Match Lit System with 3/4" Dual Flex Lines (DFLKV34) or 3/4" Dual Flex Lines + FIT300 (DFLKV34FIT300)

Original Series: CFB300, CFB350, CFB450 | H-Style Series: CFBH300, CFBH340
Any custom burners 300K and above

FOR PUSH BUTTON IGNITION INSTRUCTIONS: Follow Match Lit System installation instructions. When finished, turn to page 26 for Push Button Ignition installation instructions.

STEP 1: Locate DFLKV34 and FIT300

Parts include two 3/4" flex lines, key valve and keys (4" and 12") plus FIT300 Kit.

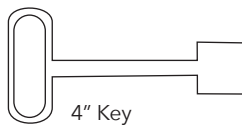

4" Key

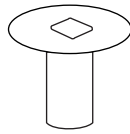

Pressure Face Plate

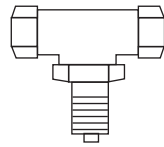

Key Valve

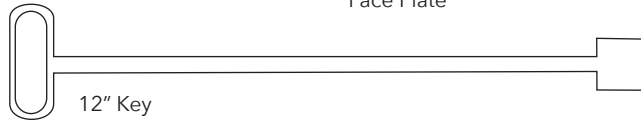

12" Key

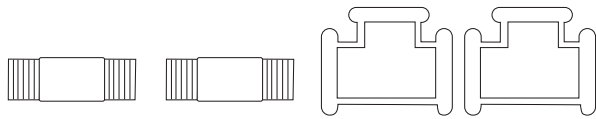

FIT300: (2) 3/4" x 3" Nipples, (2) 3/4" Tees

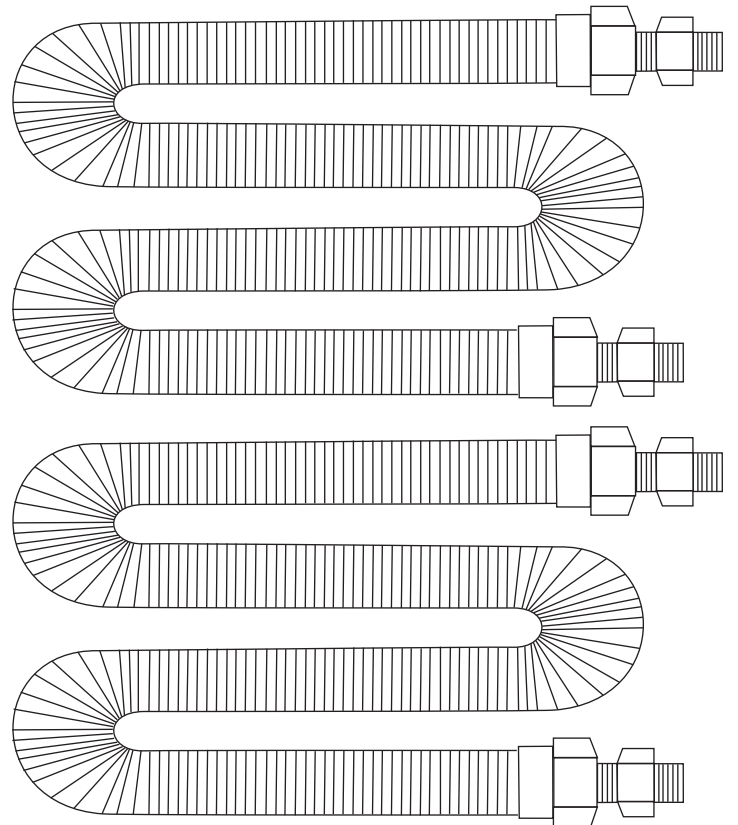

Flex Lines

STEP 2: Remove $\frac{3}{4}$ " flared fittings from each end of $\frac{3}{4}$ " flex lines.

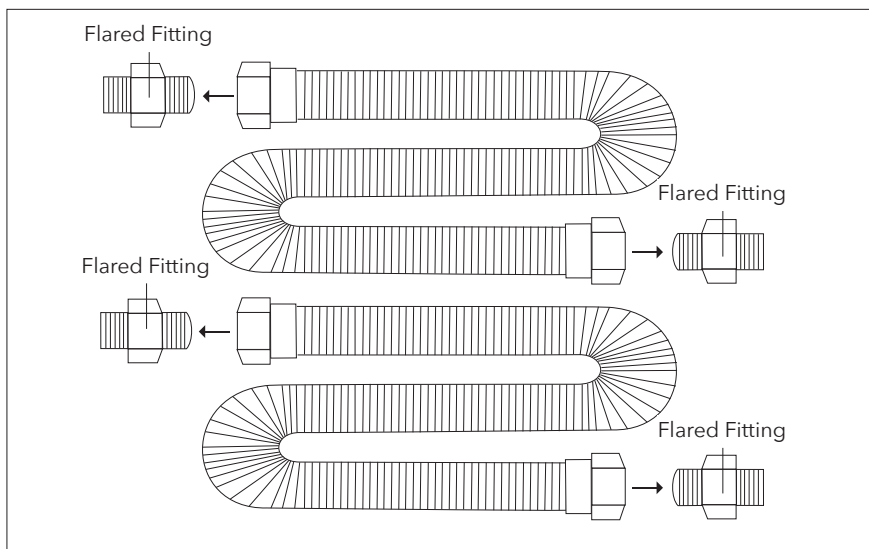

STEP 3A: Connect $\frac{3}{4}$ " x 3" pipe nipple fitting to the coupling located underneath the aluminum plate.

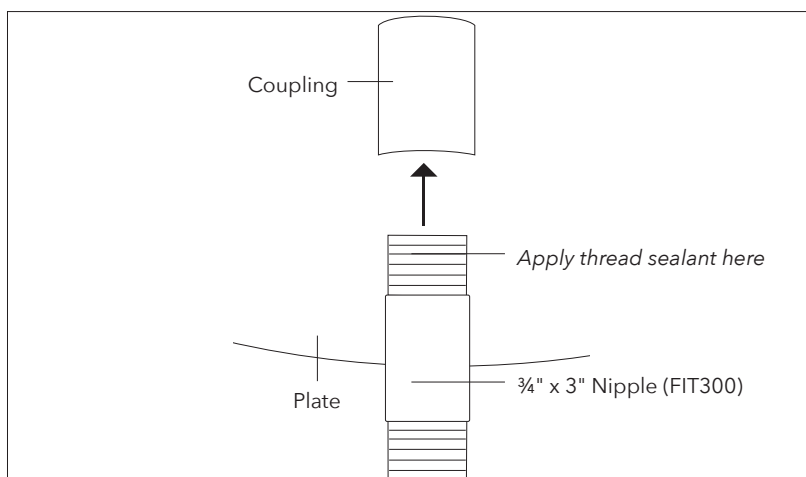

STEP 3B: (STANDARD 24 VOLT IGNITION)

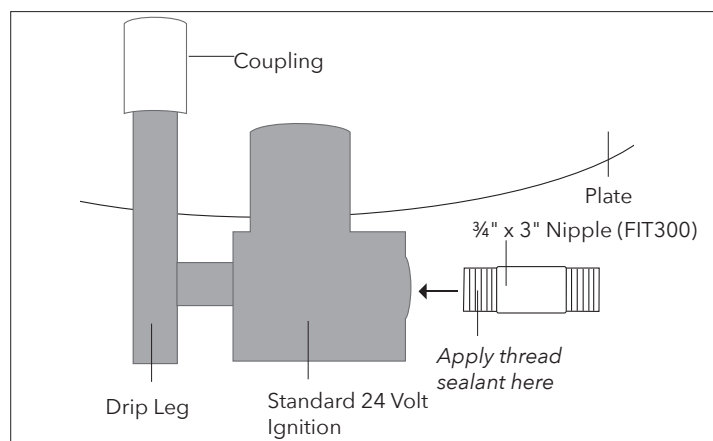

STEP 3C: (PREMIUM 24 VOLT IGNITION)

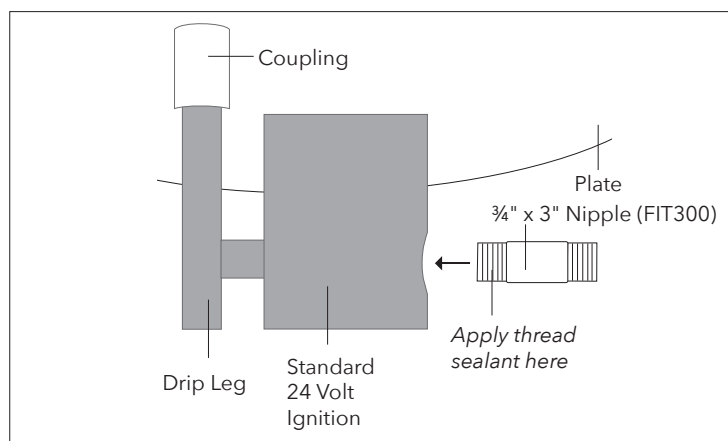

STEP 4A: Connect one 3/4" tee fittings to the connection made in Step 3 (3/4" x 3" pipe nipple under aluminum pan.)

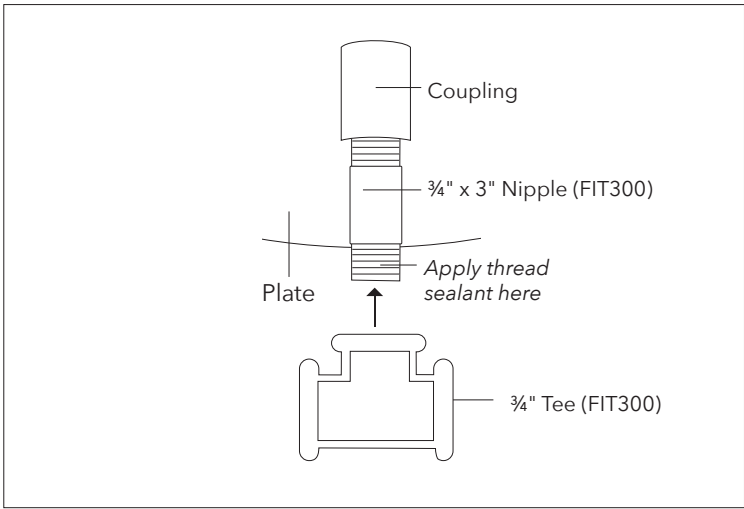

STEP 4B: (STANDARD 24 VOLT IGNITION)

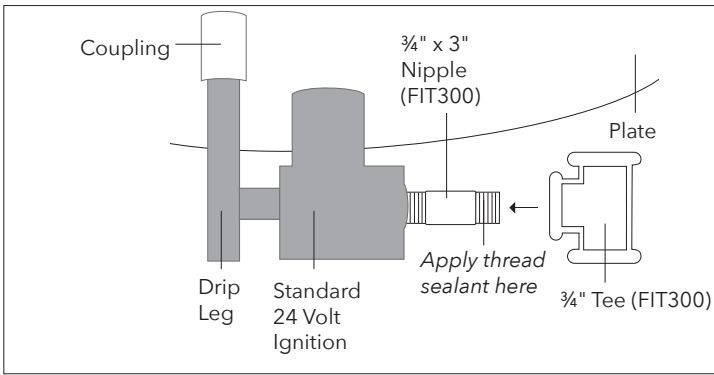

STEP 4C: (PREMIUM 24 VOLT IGNITION)

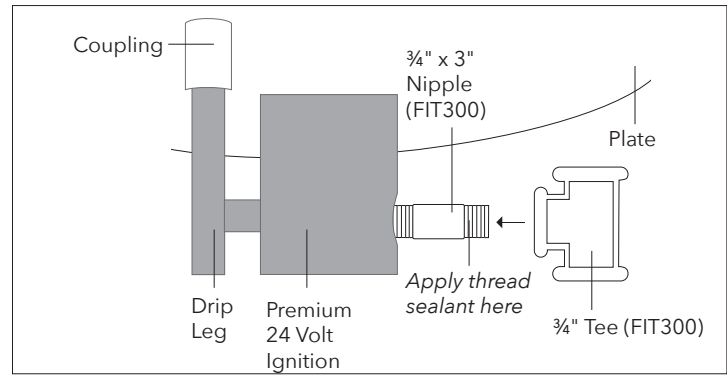

STEP 5A: Connect two of the 3/4" flared fittings removed in Step 2 to tee fitting now located underneath aluminum plate.

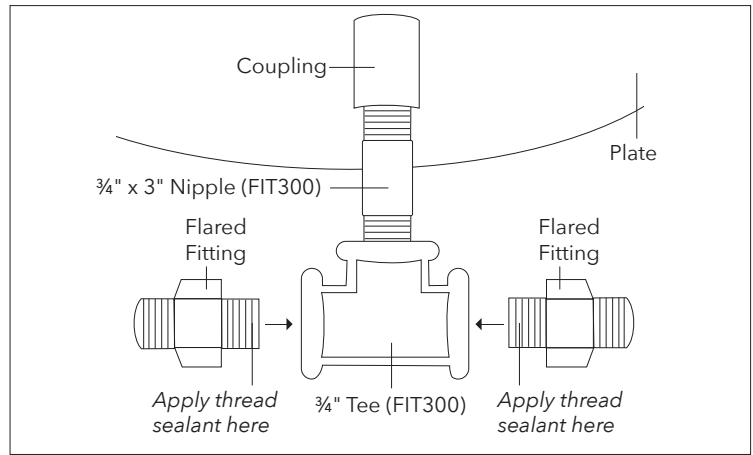

STEP 5B: (STANDARD 24 VOLT IGNITION)

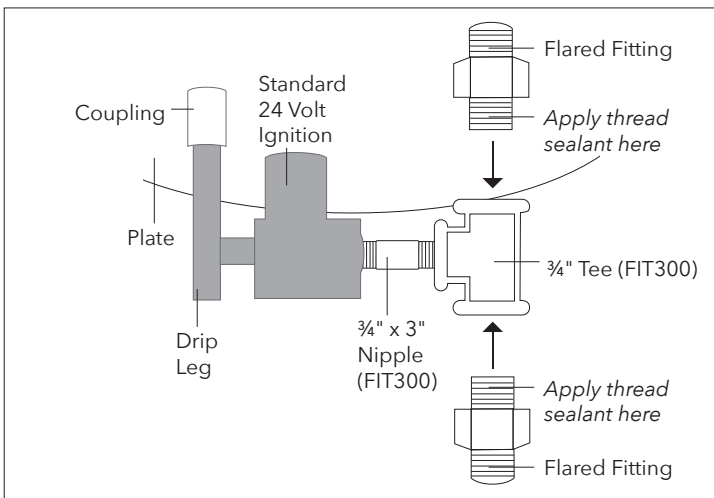

STEP 5C: (PREMIUM 24 VOLT IGNITION)

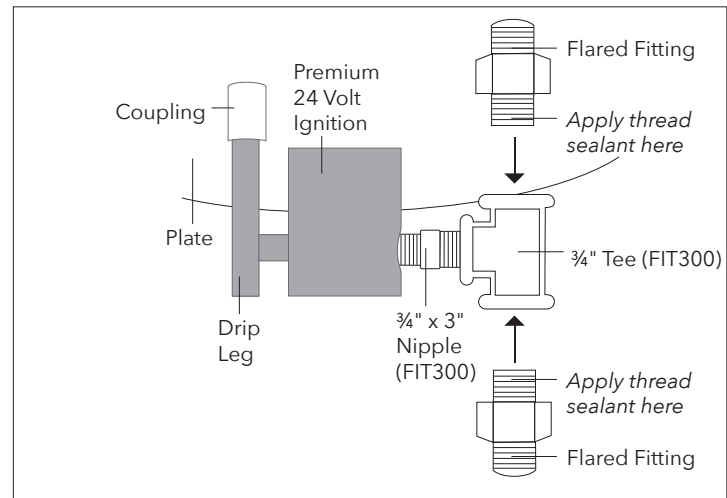

STEP 6A: Connect both 3/4" flex lines to the 3/4" flared fittings connected in Step 5. Tighten.

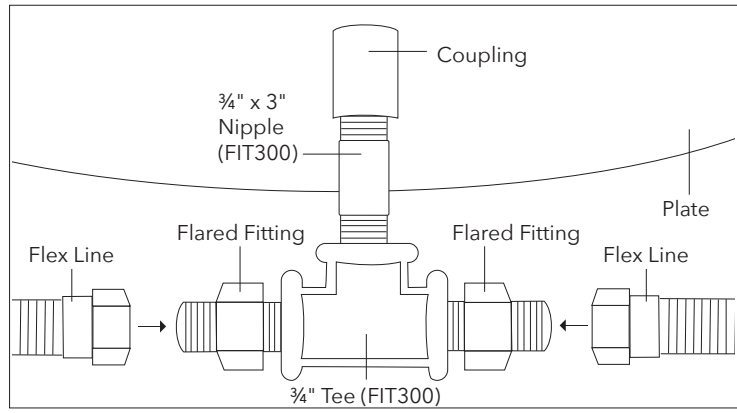

STEP 6B: (STANDARD 24 VOLT IGNITION)

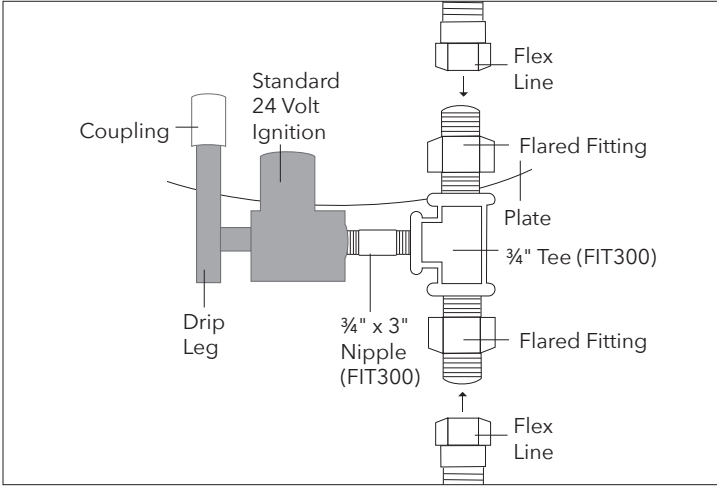

STEP 6C: (PREMIUM 24 VOLT IGNITION)

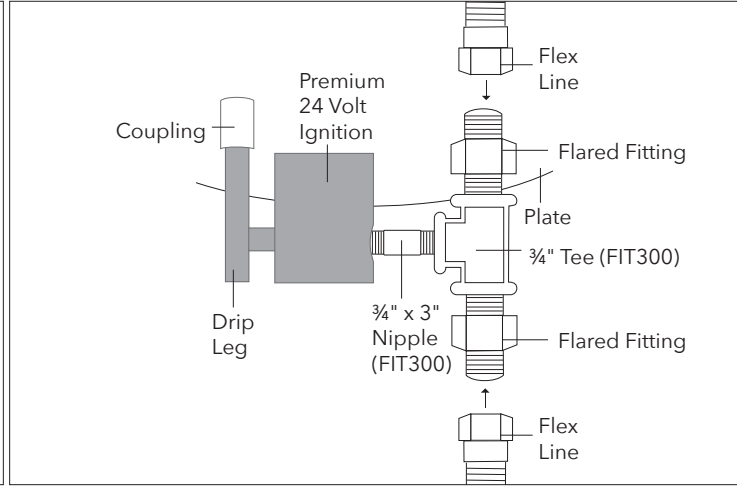

STEP 7: Connect 3/4" x 3" pipe nipple (FIT300) to the 3/4" key valve.

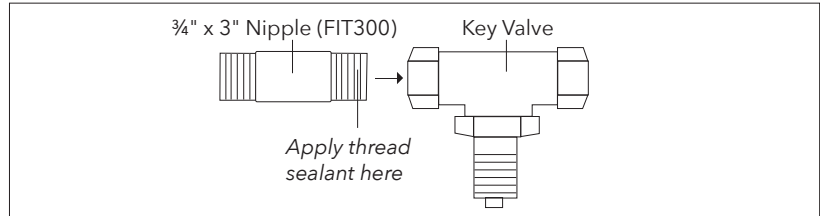

STEP 8: Connect remaining 3/4" tee fitting (FIT300) to the connection made in Step 7.

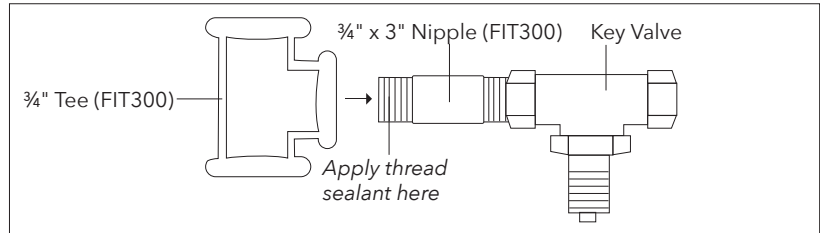

STEP 9: Connect remaining 3/4" flared fittings to the 3/4" tee fitting connection made in Step 8.

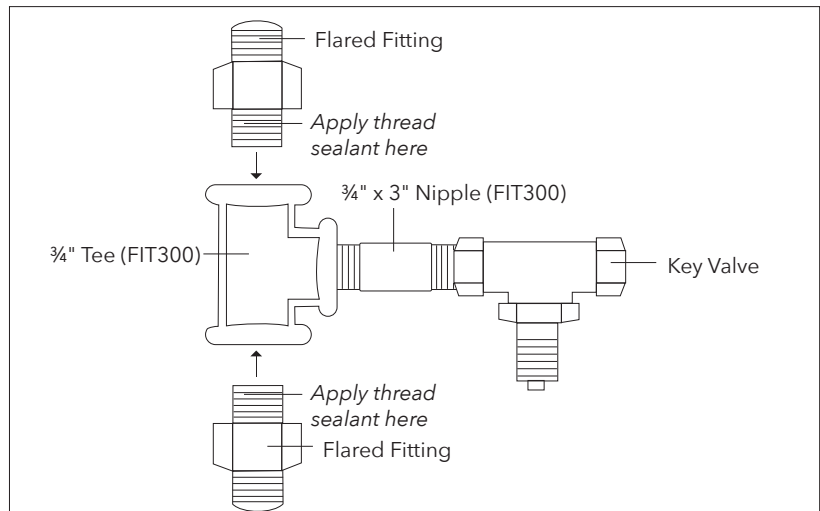

FINAL SET UP

STEP 10A: Connect available ends of 3/4" flex lines (connected to aluminum plate in Step 6) to 3/4" flared fittings connected in Step 10.

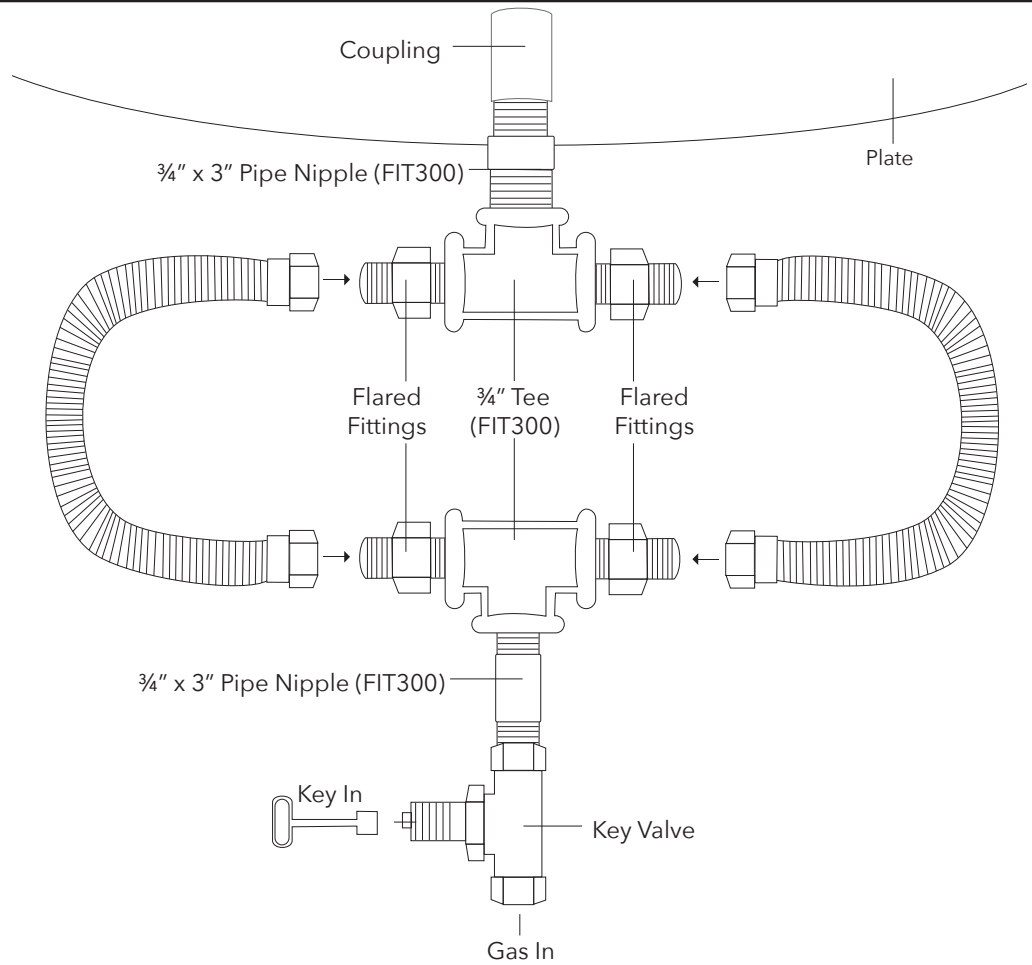

STEP 10B: (STANDARD 24 VOLT IGNITION)

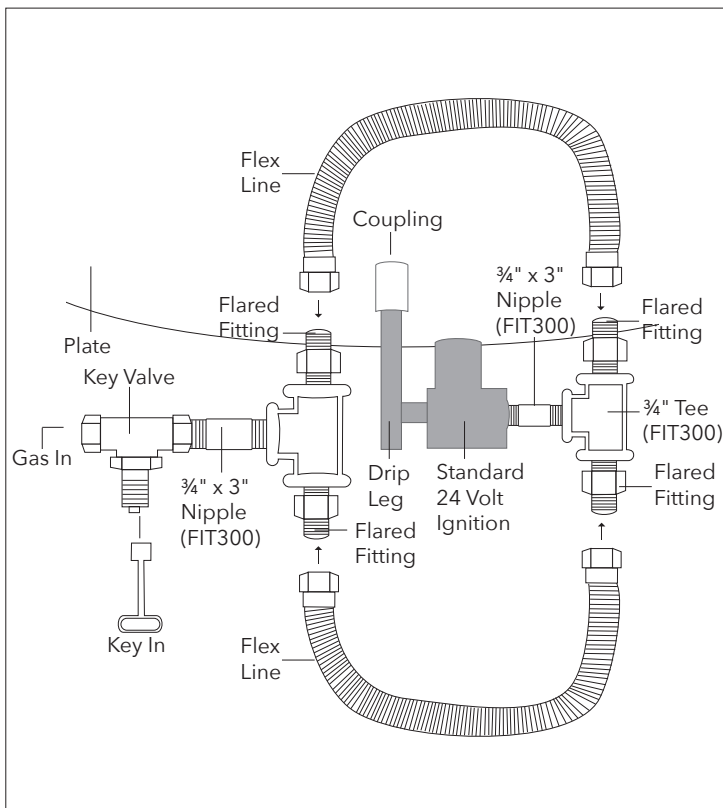

STEP 10C: (PREMIUM 24 VOLT IGNITION)

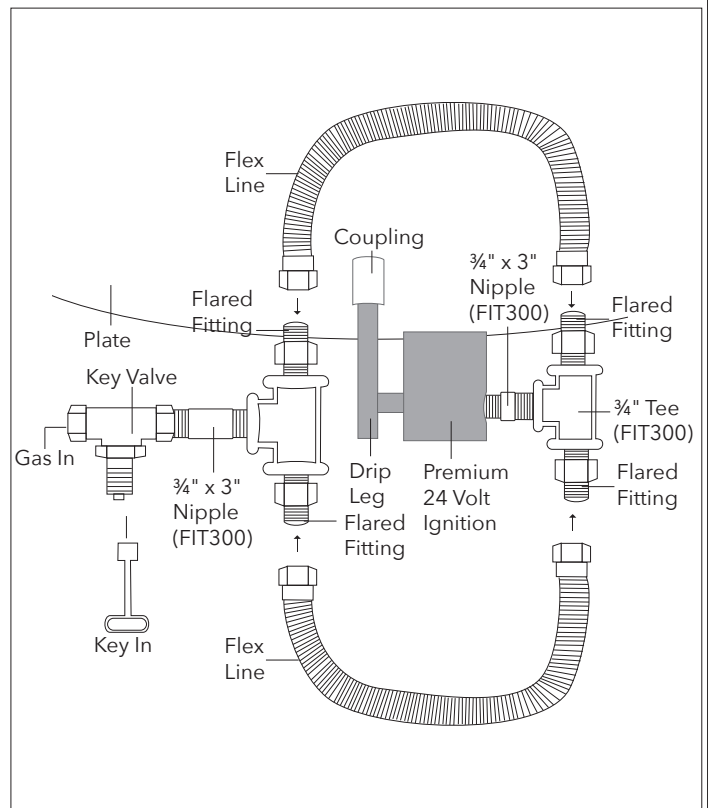

STEP 11: (STANDARD 24 VOLT AND PREMIUM 24 VOLT IGNITION SYSTEMS ONLY)

Plug ignition into three prong, above grade, NEMA Rated, outdoor specific GFCI electrical outlet or have electrician hardwire ignition into transformer.

Push Button Ignition Installation

NOTE: If the burner being installed uses a tilted jet, use the 3.0" Spark Igniter. If the burner uses a straight jet, use the 3.25" Spark Igniter.

STEP 1: To place Spark Igniter in proper position, the installer will need to drill a hole in the plate.

Measure where to drill holes by holding tip of Spark Igniter no further than **.125"** (or 1/8") away from inside edge of jet. Drill hole where base of Spark Igniter sits.

Use the 3.0" Spark Igniter

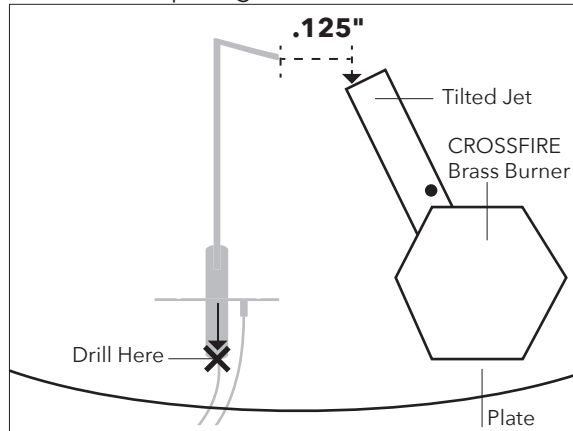

Use the 3.25" Spark Igniter

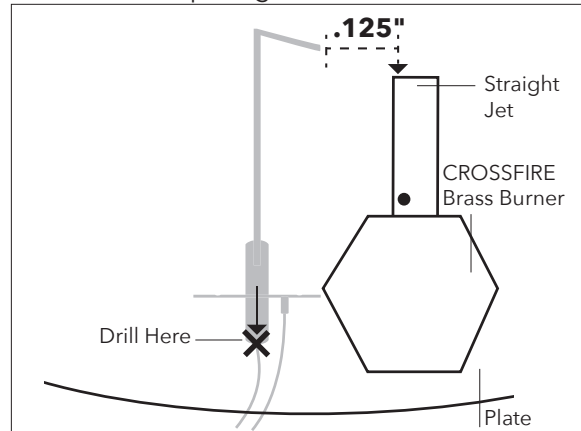

STEP 2: Place wires through drilled hole and pull through until Spark Igniter bracket is in place on plate.

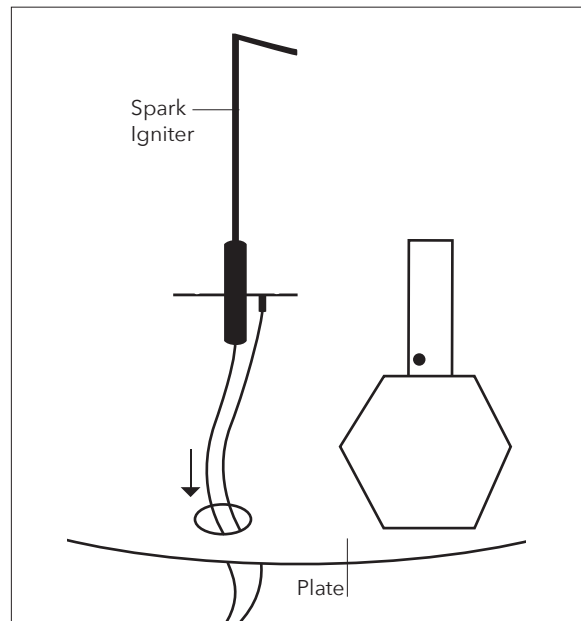
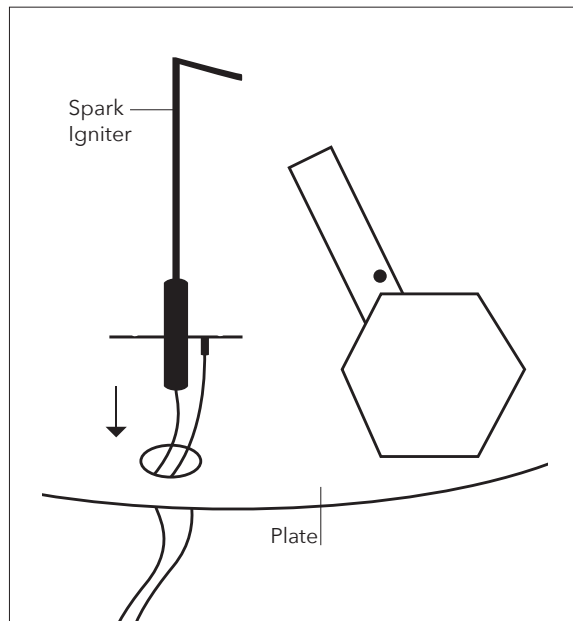

STEP 3: Screw Spark Igniter to plate. Make sure tip of Spark Igniter sits no further than **.125"** away from the inside edge of the jet.
NOTE: If Spark Igniter is too high when flush with plate, run mechanism up through bottom of plate.

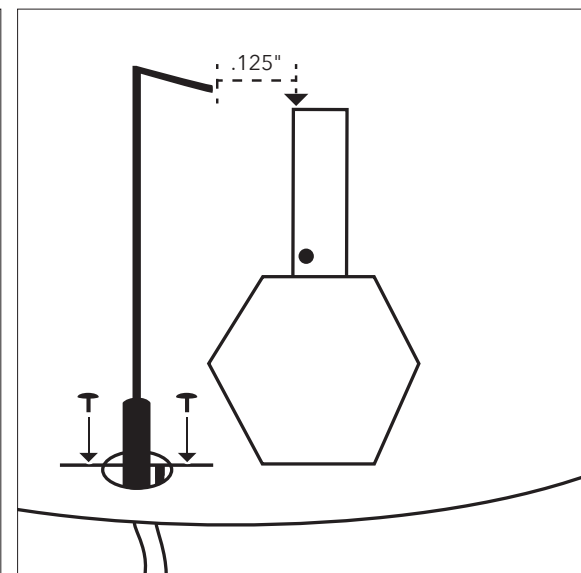
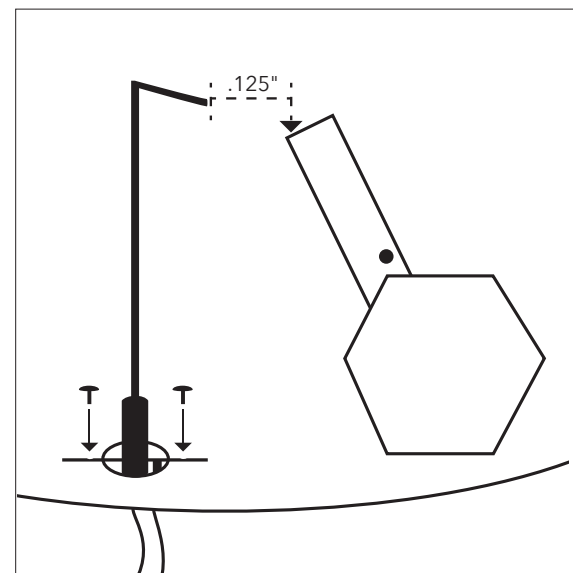

- STEP 4:** Install push button module into mounting bracket.
- 1) Unscrew button cover.
 - 2) Remove plastic nut.
 - 3) Insert washer #1 onto the button stem.
 - 4) Insert push button stem through mounting bracket hole.
 - 5) Insert washer #2.
 - 6) Put on plastic nut and turn until push button control has been secured to mounting bracket.
 - 7) Insert AAA battery into button stem.
 - 8) Screw on button cover.

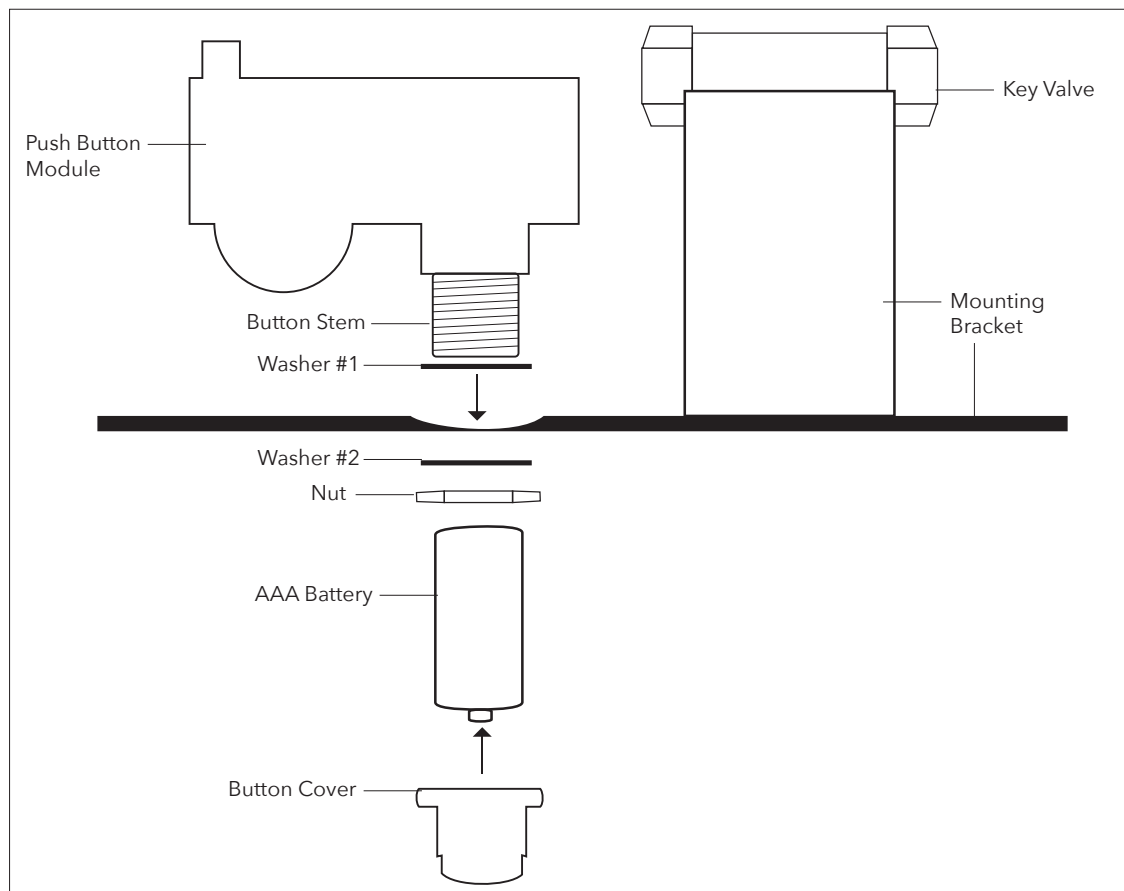

- STEP 5:** Crimp Spark Igniter wires, then slide crimped wires on to connections using needle nose pliers. Be careful not to break connectors. Wires can go in either connection.

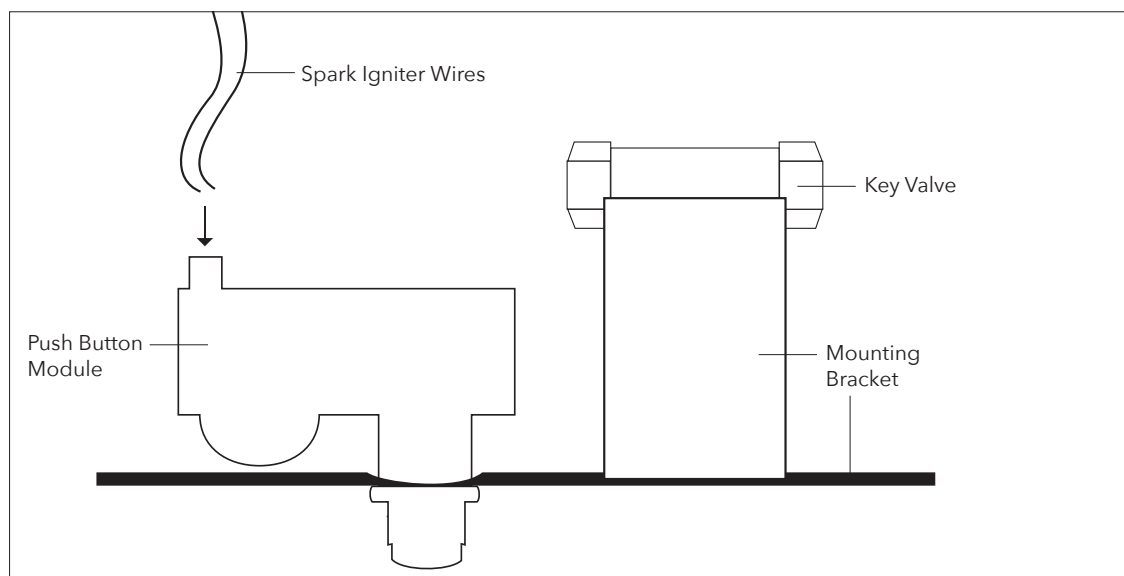

STEP 6: Test Spark Igniter and Push Button Module WITHOUT gas, making sure spark arcs from electricity to jet.

STEP 7: Test with gas. Burner should light within 5 seconds or a few clicks.

WARNING: Minimum requirement: Incorporate 1 vent on at least two opposing sides (2 vents total) at a minimum size of 18 sq. inches each (Example: 3"x 6" or larger). Installation of the vents in the mid to lower area of the enclosure is recommended. Ventilation allows for heat and/or residual fuel to escape. Failure to properly vent enclosure may result in the fire pit overheating or explosion. Overheating could lead to heat damage to internal components. Some enclosures may require more ventilation based on material, size, and extended use. The vent may serve as a drain as well when installed at bottom sidewall to prevent water build up. Always consult with local municipality regarding any local code requirements.

WARNING: Ready-to-Finish Kits come with Fire Pit Vent Kit (FPVK). Vents do not come pre-installed on Ready-to-Finish Kit as placement and installation depends on veneer. Vents to be installed by contractor on site.

Parts Glossary

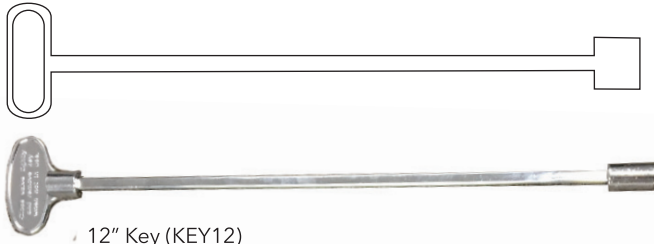

12" Key (KEY12)

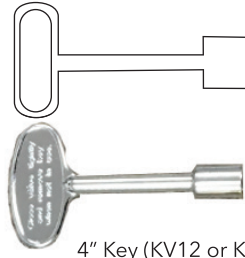

4" Key (KV12 or KV34)



Pressure Face Plate (KV12 or KV34)

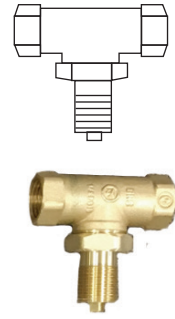

Key Valve (KV12 or KV34)

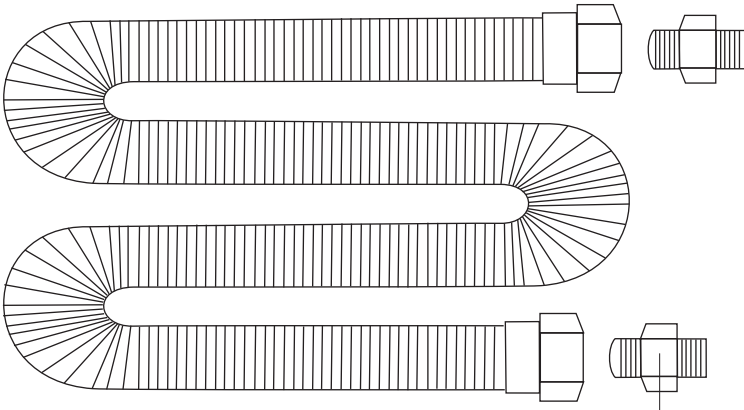

Flex Line (FL3612 or FL3634)

Flared Fitting

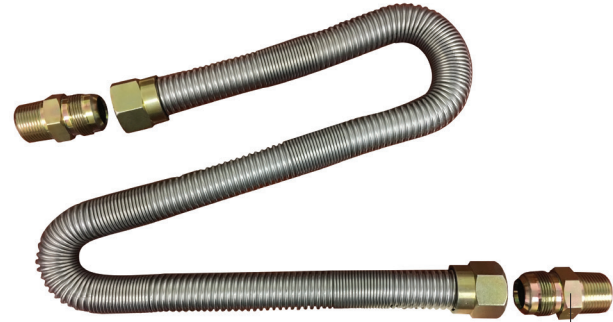

Flared Fitting

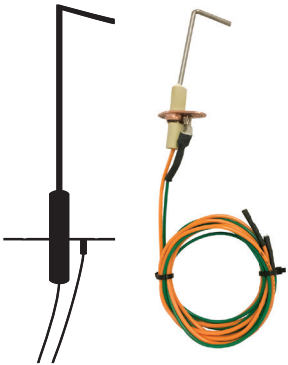

Spark Igniter (PB-SI)

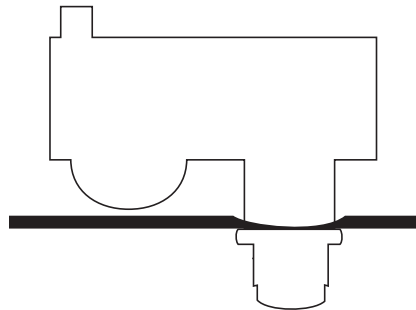

Push Button Module (PB-CM)

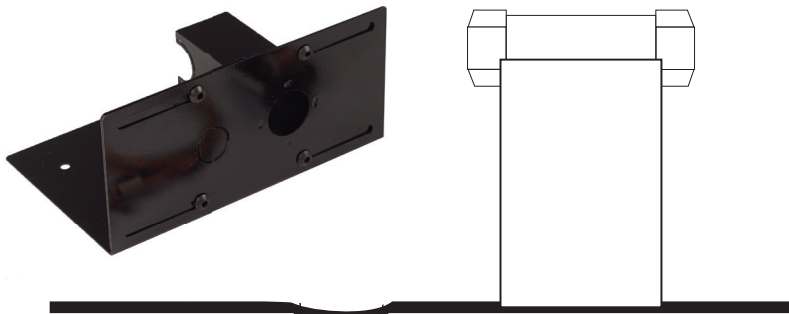

Mounting Bracket (PBMBR)

Replacement Parts

FLKV12	For use with any burner up to 120K BTU's. Kit Includes: (1) 36" L x 1/2" Diameter Flex Line + 1/2" Key Valve + 4" and 12" Key		
FLKV34	For use with any 121K - 249K BTU Burner. Kit Includes: (1) 36" L x 3/4" Diameter Flex Line + 3/4" Key Valve + 4" and 12" Key		
FLKV34FIT180	For use with any 121K - 249K BTU Burner. Kit Includes: (1) 36" L x 3/4" Diameter Flex Line + 3/4" Key Valve + 4" and 12" Key + 1/2" x 2" Nipple to connect threaded inside 3/4" Flex Line Flare Connector to 1/2" Plate Coupling		
DFLKV34	For use with any burner over 249K BTU's. Kit Includes: (2) 36" L x 3/4" Diameter Flex Lines with + 3/4" Key Valve + 4" and 12" Key		
DFLKV34FIT250	For use with any burner over 249K BTU's. Kit Includes: (2) 36" L x 3/4" Diameter Flex Lines + 3/4" Key Valve + 4" and 12" Key + (1) 3/4" x 1/2" MM Reducer Fitting and (1) 3/4" Tee for connection at 1/2" Plate Coupling + (1) 3/4" x 3" Nipple and (1) 3/4" Tee for Key Valve connection		
DFLKV34FIT300	For use with any 300K+ BTU Burner. Kit Includes: (2) 36" L x 3/4" Diameter Flex Lines + 3/4" Key Valve + 4" and 12" Key + (1) 3/4" x 3" Nipple and (1) 3/4" Tee for connection at 3/4" Plate Coupling + (1) 3/4" Tee for Key Valve connection		
FIT180	Flex Line & Key Valve Connection Fitting for use with any burner over 249K BTU's. Kit includes: (1) 1/2" x 2" Nipple. Connects 1/2" Plate Coupling to inside threaded 3/4" Flex Line Flare Connector		
FIT250	Flex Line & Key Valve Connection Fittings for 250K - 299K BTU Burner. Kit includes: (1) 3/4" x 1/2" MM Reducer Fitting and (1) 3/4" Tee for connection at 1/2" Plate Coupling + (1) 3/4" x 3" Nipple and (1) 3/4" Tee for Key Valve connection. Connects 1/2" Plate Coupling to two 3/4" Flex Lines + connection of two 3/4" Flex Lines to 3/4" Key Valve.		
FIT300	Flex Line & Key Valve Connection Fittings for 300K+ BTU Burner. Kit includes: (1) 3/4" x 3" Nipple and (1) 3/4" Tee for connection at 3/4" Plate Coupling + (1) 3/4" x 3" Nipple and (1) 3/4" Tee for Key Valve connection. Connects 3/4" Plate Coupling to two 3/4" Flex Lines and two 3/4" Flex Lines to 3/4" Key Valve.		
FL3612	36" L x 1/2" Diameter Flex Line (MM)		
KV12	1/2" Key Valve + 4" Key	KV34	3/4" Key Valve + 4" Key
KEY12	12" Key	KEY24	24" Key
DRIPLEG12	1/2" Drip Leg Kit	DRIPLEG34	3/4" Drip Leg Kit
LPRH	LP Regulator mounted on 3/8" 10' Hose with handwheel quick connect. For use up to 125k BTU's. For Use with a 20LB propane tank		
LPHOSE10	LP 3/8" 10' Hose. For use with a 20LB Propane Tank		
REGLPNG125	1/2" FNPT Inlet x 1/2" FNPT Outlet. LP/NG convertible. Up to 125K BTU's		
REGLPNG140	1/4" FNPT Inlet x 3/8" FNPT Outlet. LP/NG convertible. Up to 140K BTU's		
FPVK	Fire Pit Vent Kit: (2) 5.75" x 11.5" Vents + 18 square inches of vent area per vent		

Ignition Systems

PBIK	Push Button Ignition Kit: spark igniter rod and wire + push button battery operated control module
PB-SI	Spark igniter rod and wire
PB-CM	Push button battery operated control module
PBMBR	Mounting Bracket
3VIK-NG / 3VIK-LP	3V Ignition System
3VCM	3V Control Module
3VPA-NG / 3VPA-LP	3V Pilot Assembly (pilot tube + igniter + spark wire + igniter bracket + wind cage)
3VGV-NG / 3VGV-LP	3V 120K BTU Capacity Gas Valve
Battery Pack	3V Battery Pack
3VSTEP	3V Step Down Transformer
24VIKSC-NG / 24VIKSC-LP	Standard 24V Ignition System (Standard Capacity)
24VGVSC-NG / 24VGVSC-LP	24V 200K BTU Capacity Gas Valve (Standard Capacity)
24VIKHC-NG / 24VIKHC-LP	Standard 24V Ignition System (High Capacity)
24VGVHC-NG / 24VGVHC-LP	24V 400K BTU Capacity Gas Valve (High Capacity)
24VCM	24V Control Module for use with Standard Ignition Systems (SC & HC)
24VPA-NG / 24VPA-LP	24V Pilot Assembly (pilot tube + igniter + spark wire + igniter bracket + wind cage) for use with Standard Ignition Systems (SC & HC)
Transformer	For use with all 24V Ignition Systems (Standard Ignition and Premium Ignition)
P24VIKSC-NG / P24VIKSC-LP	Premium 24V Ignition System (Standard Capacity)
P24VCBSC	Premium 24V 290K BTU Capacity Control Box (Standard Capacity)
P24VIKHC-NG / P24VIKHC-LP	Premium 24V Ignition System (High Capacity)
P24VCBHC	Premium 24V 512K BTU Capacity Control Box (High Capacity)
P24VIKPA-NG / P24VIKPA-LP	Premium 24V Pilot Assembly (pilot tube + igniter + spark wire + igniter bracket + wind cage) for use with Premium Ignition Systems (SC & HC)
P24VIKWC	Wind Cage